



SHORT FORM CATALOG

INTRINSICALLY SAFE SIL CERTIFIED INSTRUMENTATION FOR HAZARDOUS AREAS

INDEX

| | |
|------------------------------|----|
| Company Profile | 2 |
| Manufacturing Excellence | 4 |
| Innovation | 6 |
| Training and Development | 8 |
| Approvals and Certifications | 10 |
| Worldwide Presence | 11 |
| Products | 13 |
| Product Selector | 16 |
| D5000 Series | 21 |
| Safety Relays | 33 |
| D1000 Series | 45 |
| EI1000ADP Series | 56 |
| D6000 Series | 59 |
| D2000 Series | 67 |
| Power Supplies | 75 |
| D9000 Series | 83 |
| T3000 Series | 87 |
| Online Information | 90 |

COMPANY PROFILE

History

In 1970 Glisente Landrini founded Elcon Instruments, which has been acknowledged as an international leader in the design and manufacturing of Intrinsically Safe products and systems.

Mr. Landrini started G.M. International to provide state of the art SIL rated products and services to support Intrinsically Safe applications in Oil & Gas, Petrochemical and Pharmaceutical Industries.

The Company was founded in 1993, but the core Management experience remarkably exceeds over 40 years of qualified activity in hazardous locations and industrial electronics.

G.M. International's products have been successfully installed in plants all over the world, including Europe, Russia, North America, Middle and Far East and China.

G.M. International's products interface all wiring between safe and hazardous areas and represent a fundamental, yet often under-estimated, layer of the instrumentation package.

Intrinsically Safe isolators provide energy limitation to protect from risks of explosion while providing the highest grade of availability to guarantee both continuous operation and effectiveness of the safety layer.

G.M. International has obtained SIL 3 FSM approval by TÜV according to IEC61508:2010 standard, and its products are certified up to SIL3, offering the greatest levels of functional safety for high integrity and critical applications.



*Glisente Landrini
President and Managing Director*



Headquarters in Italy

Goals and Values

- Designing and manufacturing Intrinsically Safe Instruments certified up to SIL 3
- Understanding, managing and reducing risks
- Preventing accidents
- Achieving 100% customer satisfaction
- Demonstrating social responsibility and contributing to sustainable development
- Minimizing impact on environment and climate, and creating a safe and healthy working environment
- Being imaginative and stimulating new ideas
- Being truthful and acting with integrity
- Working together and sharing experience
- Striving for simplification and clarity, focusing on value-adding activities

Health Safety Environment

G.M. International conforms to latest HSE standards and to all local Health and Safety regulations and requirements with continuous and extensive personnel formation and hands-on training. Management is committed to the highest achievable HSE level throughout all stages of our activities and, it is our policy to protect our employees, customers, subcontractors and the community. Our objective is to reduce risks to the lowest level in order to reach a HSE goal of zero incidents, confirmed by OHSAS 18001:2007 certification.

Code of Ethics

All personell is highly qualified, experienced and continuously trained. G.M. International employees adhere to a strict code of ethics approved by the Board of Directors.

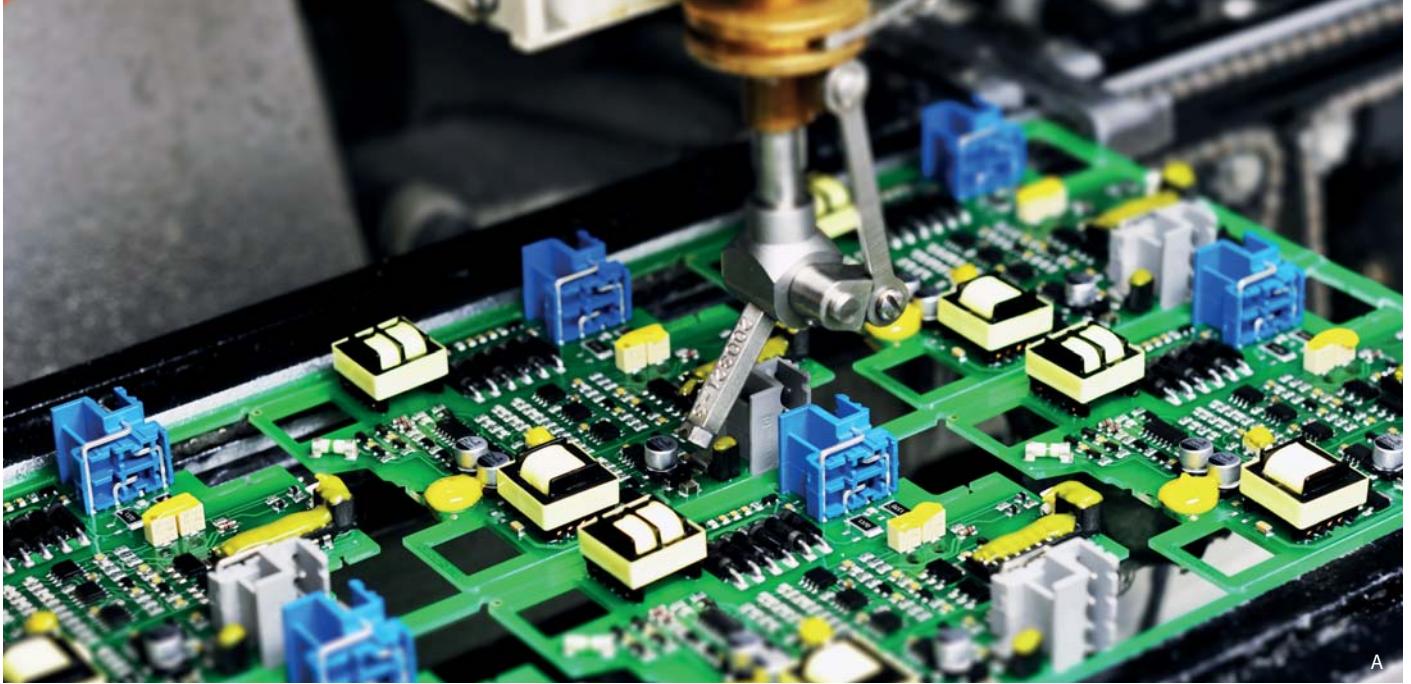

MANUFACTURING EXCELLENCE

Laser Marking

All markings are engraved using a state-of-the-art laser etching machine; permanent in every environmental condition.

Marking includes complete wiring diagrams, terminal block number assignments and certification data.

Product Traceability

All products follow a strict traceability standard. From the batch of components to customer assignment through every manufacturing and testing steps, all data of individual modules are stored.

Starting from the serial number, the complete history of any module can be traced through all production phases.

Protective G3 Coating

All units are treated with a "G3" compliant silicon based coating.

Such tropicalization is applied to improve electrical characteristics, as well as to protect from harsh environmental conditions.



B



C

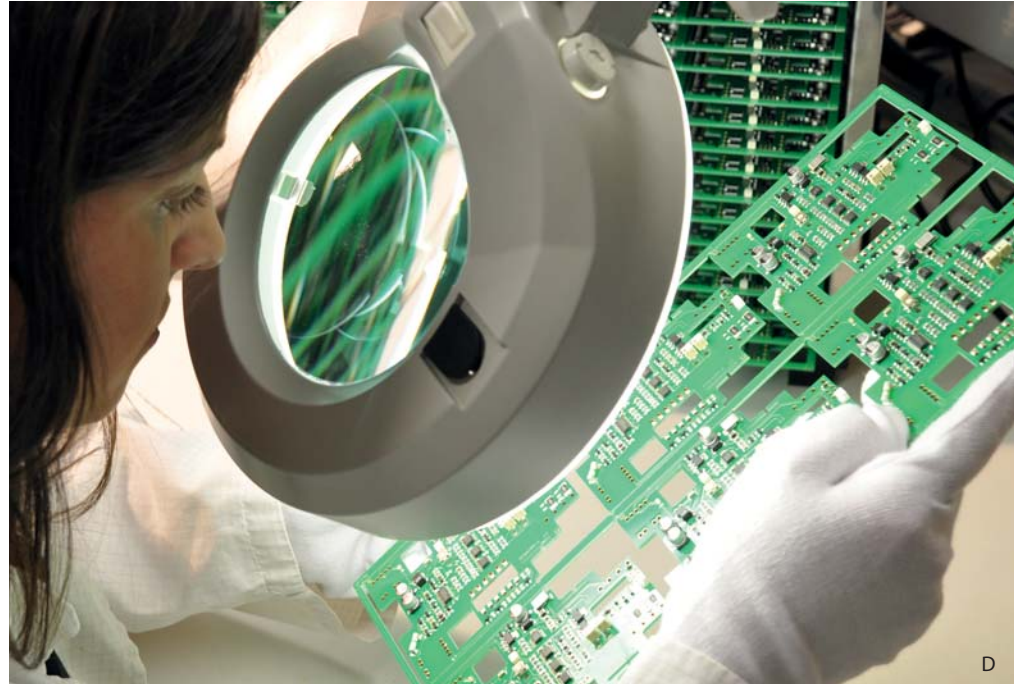

D

Made in Italy

The whole product range are proudly assembled, calibrated and tested in our own facilities in Villasanta, near Milan in ITALY, utilizing the latest technologies and machinery.

Manufacturing Facilities

Having complete control on the manufacturing process ensures the highest level of quality and guarantees the greatest flexibility for all customers' requirements with improved delivery time for large or small orders alike.

Manufacturing equipments are constantly renewed and updated; Automatic Test Equipment, specifically developed by our engineering team, are constantly checked and calibrated against traceable standards to ensure accuracy and repeatability.

The entire manufacturing process is SIL 3 certified by TÜV.

100 % Testing

Each and every manufactured product undergoes rigorous and automated test and calibration procedures. Test bench calibration is verified several times during the day to guarantee correct and repeatable results. Product field return rate, verified according to ISO 9000:2008 records, is lower than 0.1%.

A. G3 Coating
 B. Assembly Line
 C. Automated Pick and Place
 D. Visual Inspection

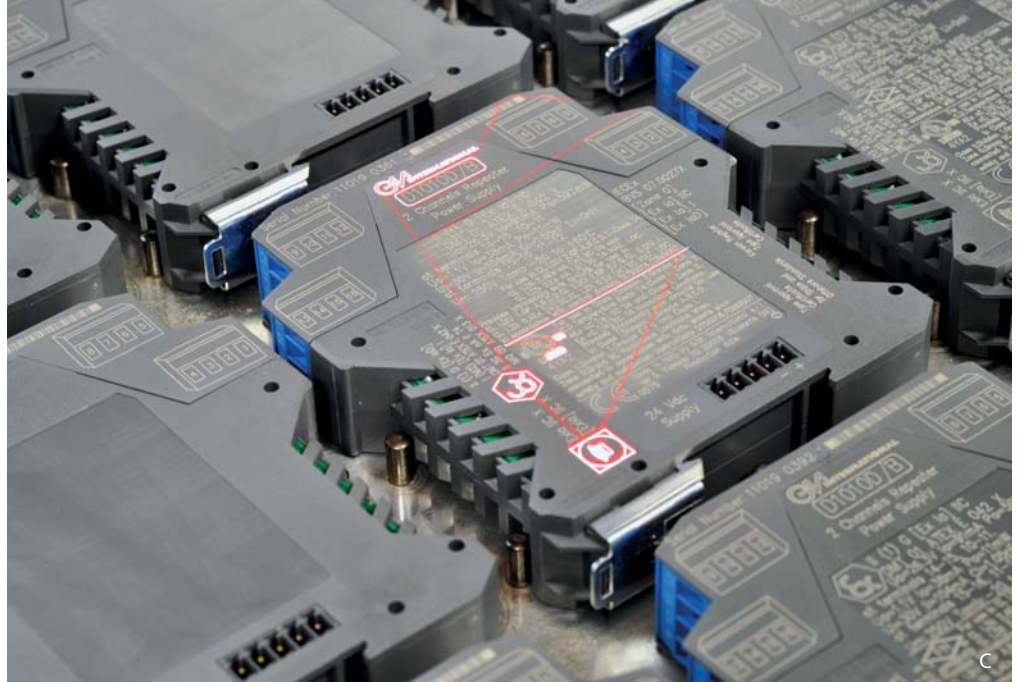

INNOVATION

Design

D5000 and D6000 series modules use embedded Planar Transformers to guarantee the greatest reliability, accuracy and stability, as well as low manufacturing costs.

We strive to use the best industry components, qualified as a minimum for operations up to 85°C, and use advanced designed techniques to improve performances and quality. D5000 series does not use electrolytic capacitors and has obtained TÜV certification for 20 years lifetime.

Assembly Technology

We make use of the latest assembly technology such as SMD mounting of most components including terminal blocks and transformers.

Soldering is performed using reflow technology, industry highest standard. Automatic optical verification of all assembled plates is performed at the end of the assembly process to eliminate all flaws at the earliest stage.

Cutting Edge Technology

Automated assembly lines allow us to improve quality and delivery time thus lowering manufacturing defects. Constant investments are made in the production line to keep abreast with the latest technology.

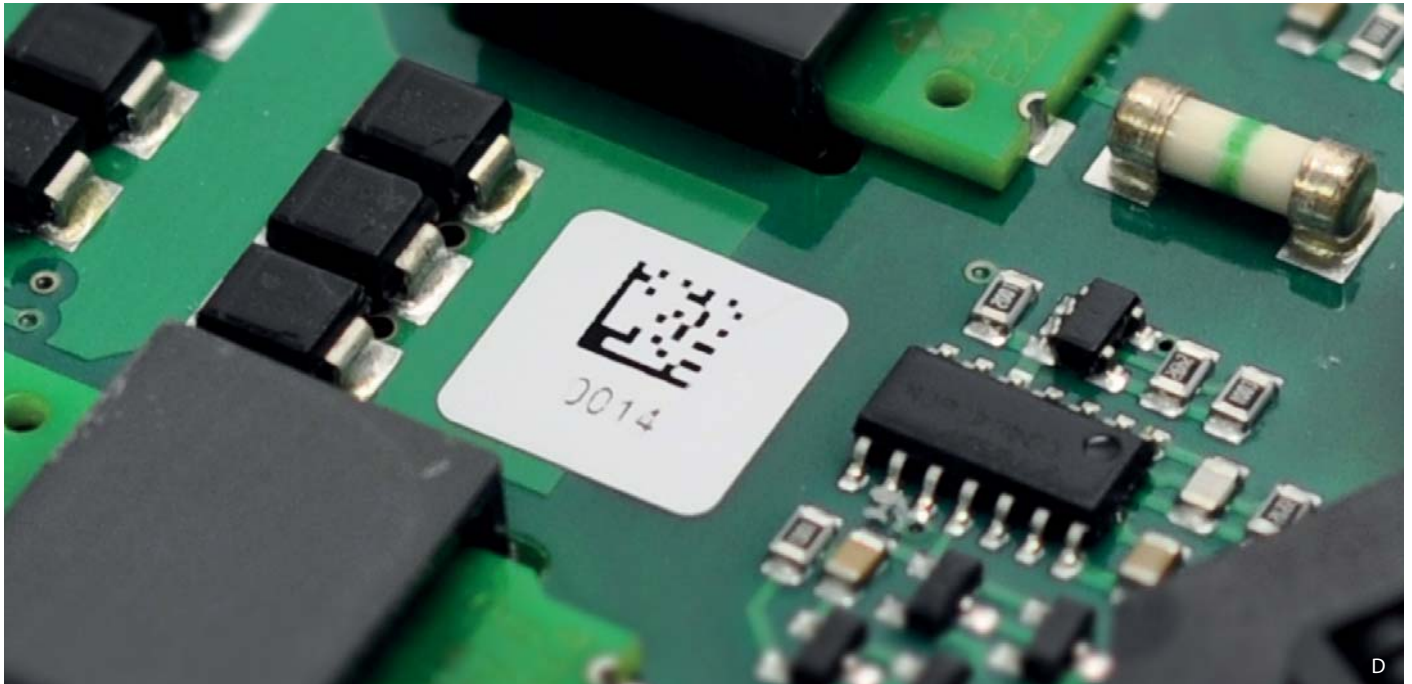

Research and Development

G.M. International gives strategic importance to R&D activities and delivers products conforming to the latest standards.

Research, development and manufacturing are strengthened through large investments. Over 20% of the company employees are devoted to research, development and engineering of our products.

R&D personnel works closely with other company teams and keeps tight relationships with customers worldwide; together with our many years of experience in all fields of applications, these are key factors to deliver excellent products that fulfill requirements and anticipate market trends.

R&D department is also covered by a FSM SIL 3 Certification by TÜV.



Quality

Quality is crucial to achieve customer satisfaction and market success.

G.M. International's products satisfy customers' expectations and meet the specifications of international standards.

Safety, performance, reliability and product documentation are the basic principles of product quality. G. M. International has obtained ISO 9001:2008 in 2006.

A. Automated Pick and Place
 B. Selective Soldering
 C. Laser Marking
 D. Product Traceability



TRAINING AND DEVELOPMENT

Continuous Education

Continuous training and improvement of the staff's skills and capacities are key points to enhancing company performances and customer's satisfaction.

G.M. International offers extra courses to raise our employees awareness of the company products and their use, in addition to mandatory training on HSE, Quality and manufacturing/testing practices.

Customer Support

G.M. International considers service as an integral part of customer's requirements and satisfaction.

Among the services we offer:

- Cabinet assembly according to customer's specification and worldwide EX standards
- System Engineering
- Custom solutions tailored to customer's special requests
- ISO 9000:2008 certified post sales assistance service
- Factory Acceptance Tests (FAT) on products and assembled cabinets that can be staged in our facilities in Villasanta (MB) – Italy, at any of our subsidiaries or in the facilities of our worldwide system integrator partners



Customer Training

Special courses for engineering companies, end users and system integrators are also given both in-house and at customers sites on topics such as Intrinsic Safety (I.S.) and SIL levels of a Safety Instrumented System (SIS). Specifically, our SIL courses based on our SIL manual, have proven to be highly informative and have gained strong popularity.

G.M. International is a course promoter of the TÜV Rheinland Functional Safety Program for Safety Instrumented Systems (SIS) trainings, see our website for available dates. The main objective is to provide engineers involved in safety instrumented systems with elementary and necessary knowledge of functional safety, based on IEC61508 and IEC61511.

Safety Instrumented Systems

This Manual is a practical aid for the analysis, installation and maintenance of safety instrumented systems and associated components and will hopefully serve as a guide for understanding and implementing procedures into practical applications.

It represents an effort to share the results achieved in many years of research and experience in the field, with anyone willing to approach Safety Related Systems. The manual is for the thousands of professionals employed in process industries who work with safety instrumented systems and who are expected to follow the appropriate industry standards.



A. Global Sales Team
 B. Functional Safety Engineer course held by Tino Vande Capelle, Functional Safety Services Director
 C. SIL Manual



PESO



APPROVALS AND CERTIFICATIONS

Intrinsically Safe Products

G.M. International's products have been granted I.S. certificates from the most credited Notified Bodies in the world.

Certificates are available for ATEX (Europe), IECEx (International), USA and Canada, EAC-EX (Russian and Ukrainian), China, India, Japan, Brazil.

All certificates are available for download from our website.

IEC61508:2010 SIL Certifications

G.M. International offers a wide range of products that have been proved to comply with the most severe quality and safety requirements.

IEC61508 and IEC61511 standards represent a milestone in the progress of industry in the achievement of highest levels of safety through the entire instrumented system lifecycle.

The majority of our products are SIL certified as well as our design, manufacturing and administrative facilities (FSM); reports and certificates from TÜV and EXIDA are available for download from our website.

Maritime Type Approval

G.M. International offers Type Approval Certificates for its line of Intrinsically Safe Isolators and Power Supplies for use in Maritime and Offshore applications.

Certificates were issued by Det Norske Veritas and by Korean Register of Shipping.



WORLDWIDE PRESENCE

We are there, wherever you need

G.M. International provides local pre and post sales support through its 7 direct subsidiaries and numerous agents and distributors in more than 55 countries.

Our authorized sales network ensures a fast response wherever you are.

Visit our website www.gmintsr.com to find an expert near you and take advantage of a global partnership with G.M. International.

Americas

- Argentina
- Canada
- Chile
- Colombia
- Mexico
- Trinidad and Tobago
- USA

Africa

- Algeria
- Egypt
- Morocco
- Nigeria
- Tunisia

Asia - Pacific

- Australia
- Cambodia
- China
- India
- Indonesia
- Japan
- Korea
- Laos
- Malaysia
- Myanmar
- New Zealand
- Philippines
- Singapore
- Thailand
- Vietnam

Europe

- Austria
- Estonia
- France
- Germany
- Greece
- Hungary
- Ireland
- Italy
- Latvia
- Lithuania
- Norway
- Poland
- Romania
- Russia
- Spain
- Sweden
- The Netherlands
- Turkey
- Ukraine
- United Kingdom

Middle East

- Iran
- Jordan
- Kuwait
- Libya
- Oman
- Qatar
- Saudi Arabia
- United Arab Emirates





Enhanced Intrinsic Safe Isolators
D5000



Safety Relays for High Integrity Applications

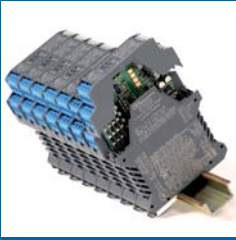

Intrinsic Safe Isolators
D1000



Non Intrinsic Safe Isolators
D6000



Intrinsic Safe Multiplexer System
D2000



SIL Certified Enhanced Power Supply



Surge Arresters
D9000



Intrinsic Safe Loop Indicator
T3000

PRODUCTS

PRODUCTS OVERVIEW

Safety, performance and reliability: our products, our promises

From the latest intrinsically safe isolators to safety relays for high integrity applications, to enhanced power supply units and systems, here you can find a complete overview of the product range of GM International.

A product selector will help you find the correct series or product for your systems. Detailed descriptions of our product series with general features, related accessories and technical selection tables to support you with the product that suits your application.

Our products are certified up to SIL 3, offering the highest levels of functional safety for high integrity and critical applications.

Get inspired!



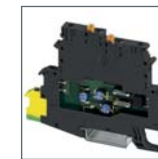
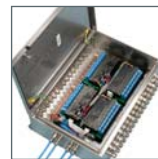
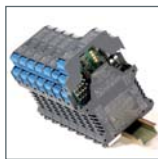















Visit our website for further information: www.gmintsr.com









ICONS

The following is a descriptive list of the icons that appear in this section:







Intrinsically Safe

-  Transmitter
-  Switch or Proximity
-  I/P Converter
-  Proximity
-  Current or Voltage Signal
-  Magnetic Pickup or Proximity
-  Current Signal
-  Load Cell Strain Gauge
-  Thermocouple or RTD 4-wires
-  Vibration Sensor
-  Thermocouple or RTD 3-wires
-  RS-485
RS-422 Serial Communication Protocol
-  Thermocouple or Voltage Signal
-  D2010M
D2030M For connection to field units D2010M, D2030M
-  RTD 3-wires
-  Isolated AC/DC Power Supply
-  Electrovalve
-  LED
-  Switch-over Relay

Non Intrinsically Safe

-  Safety Relay
-  Electrovalve
-  LED
-  Fire and Gas System
-  Visual Alarm
-  Audible Alarm
-  Isolated AC/DC Power Supply

Features

-  **SIL 3** SIL 3 Level according to IEC 61508, IEC 61511
-  **SIL 2** SIL 2 Level according to IEC 61508, IEC 61511
-  Pulse Test compatible
-  Diagnostics available
-  MODBUS MODBUS RTU available
-  TB Only for Termination Board
-  Configurable via PC

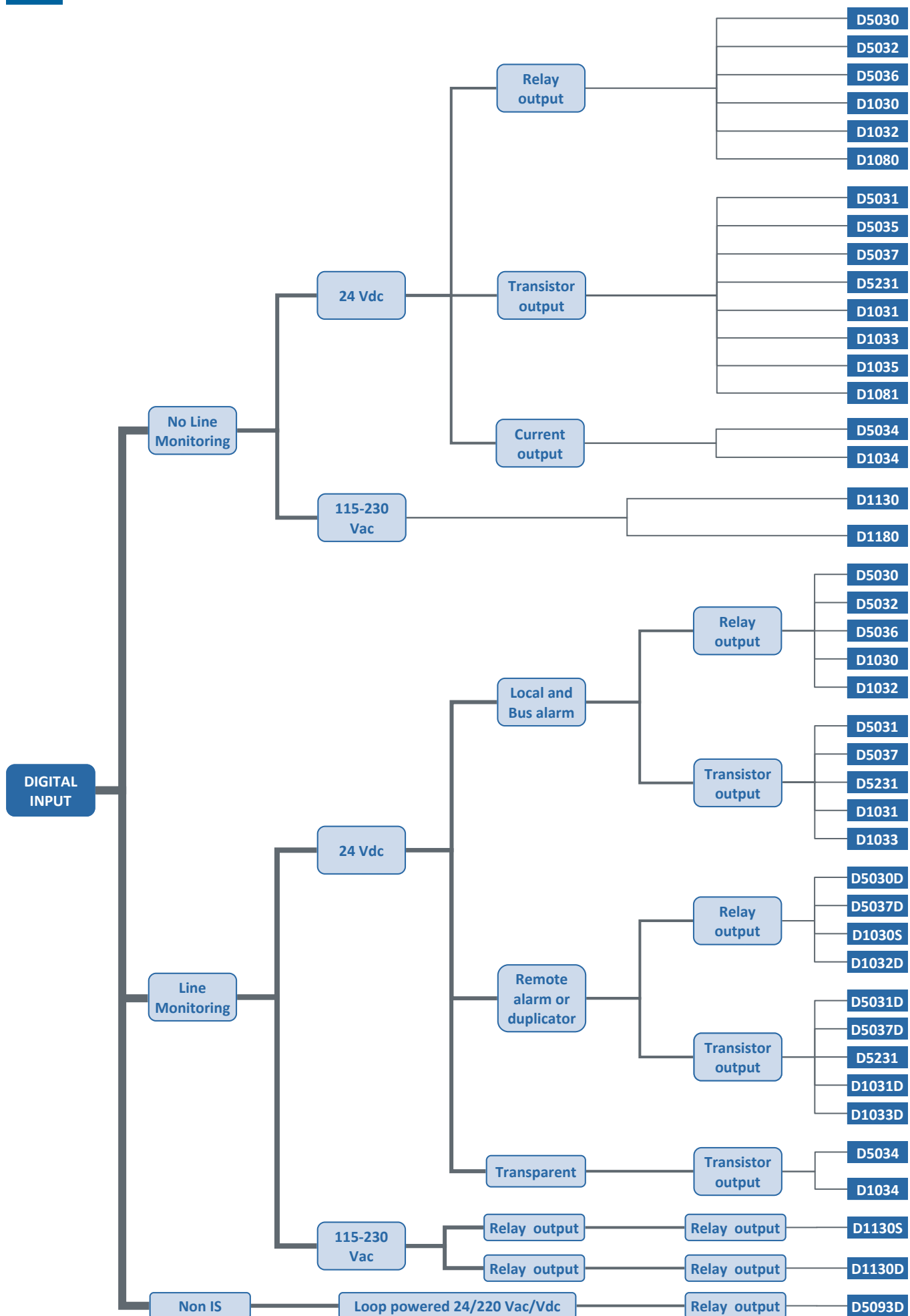

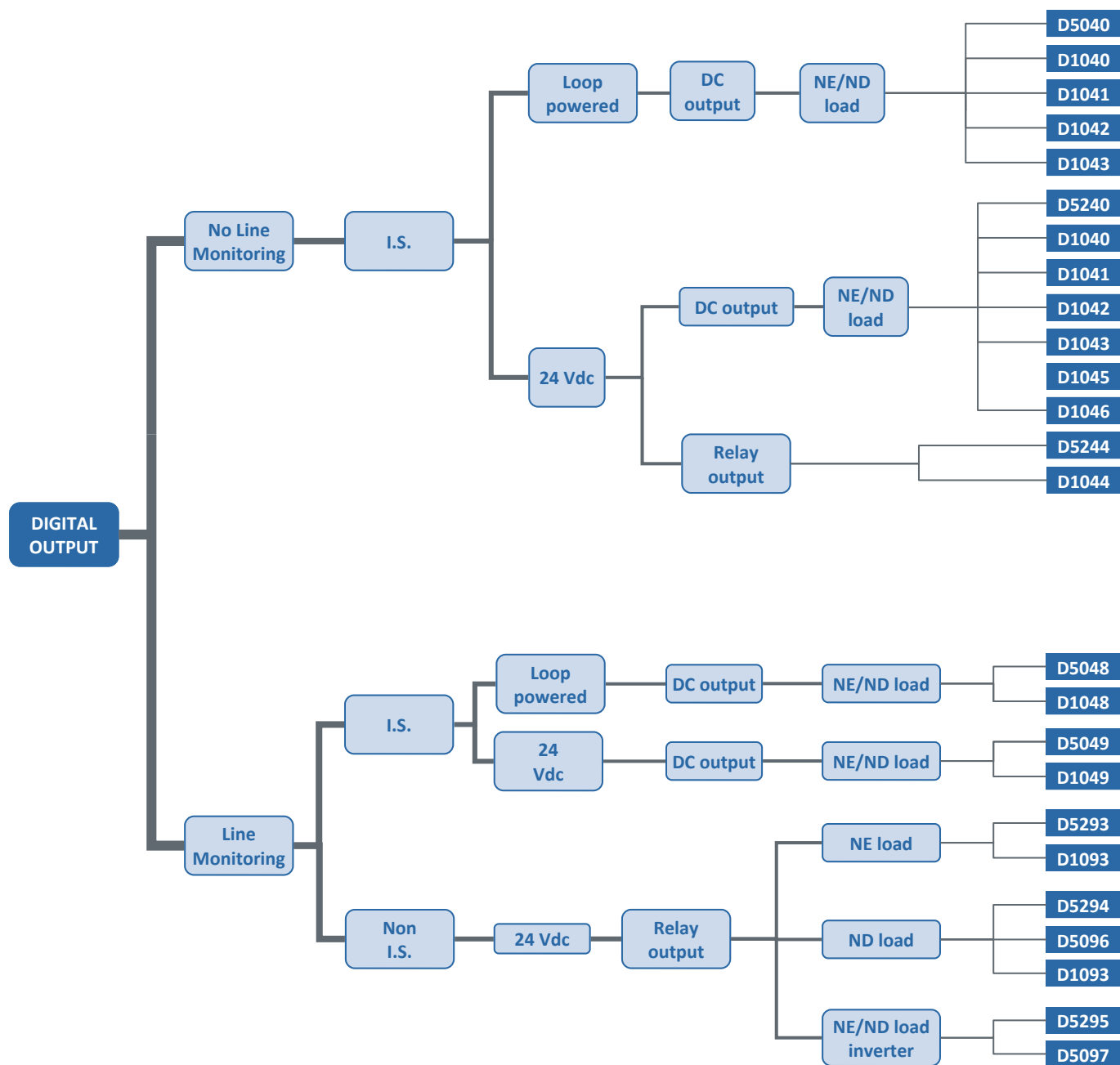

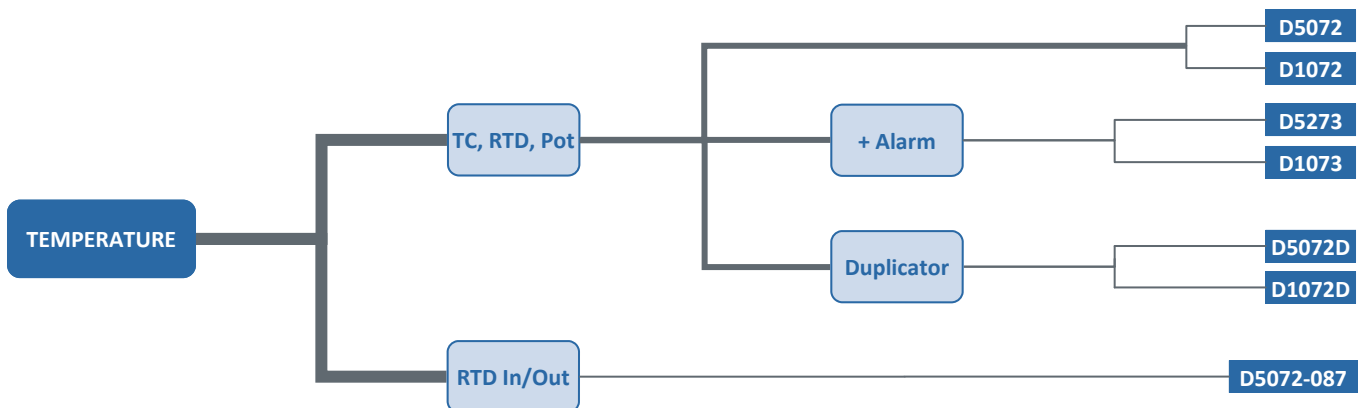
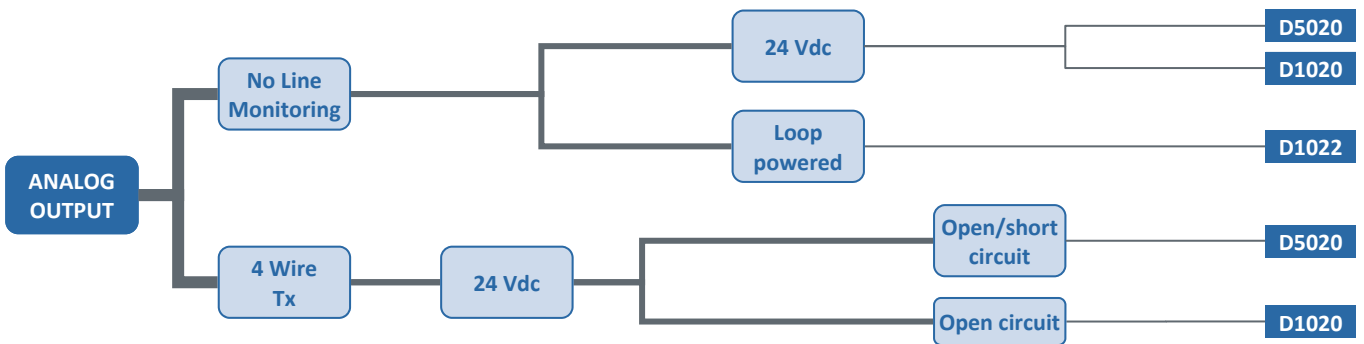
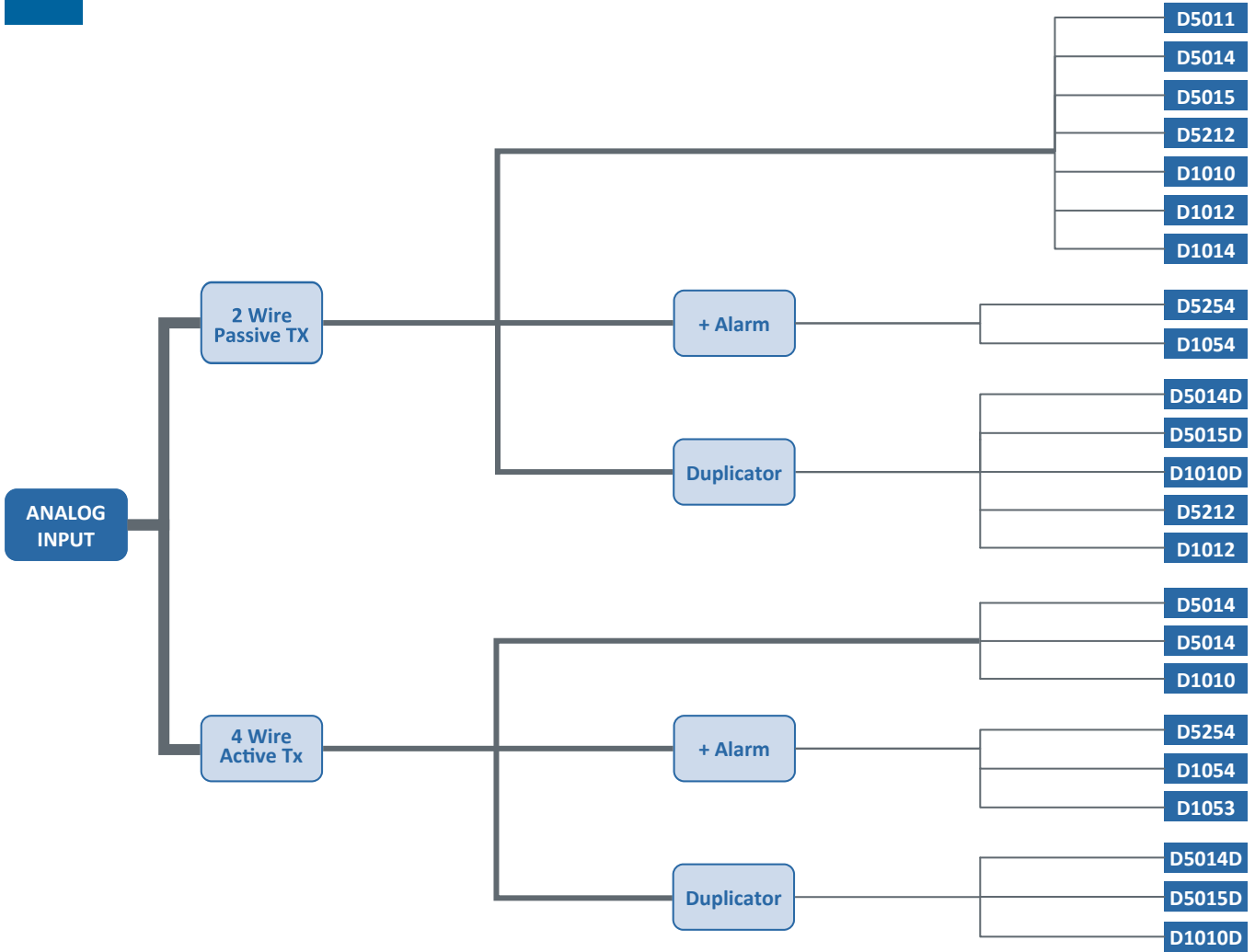

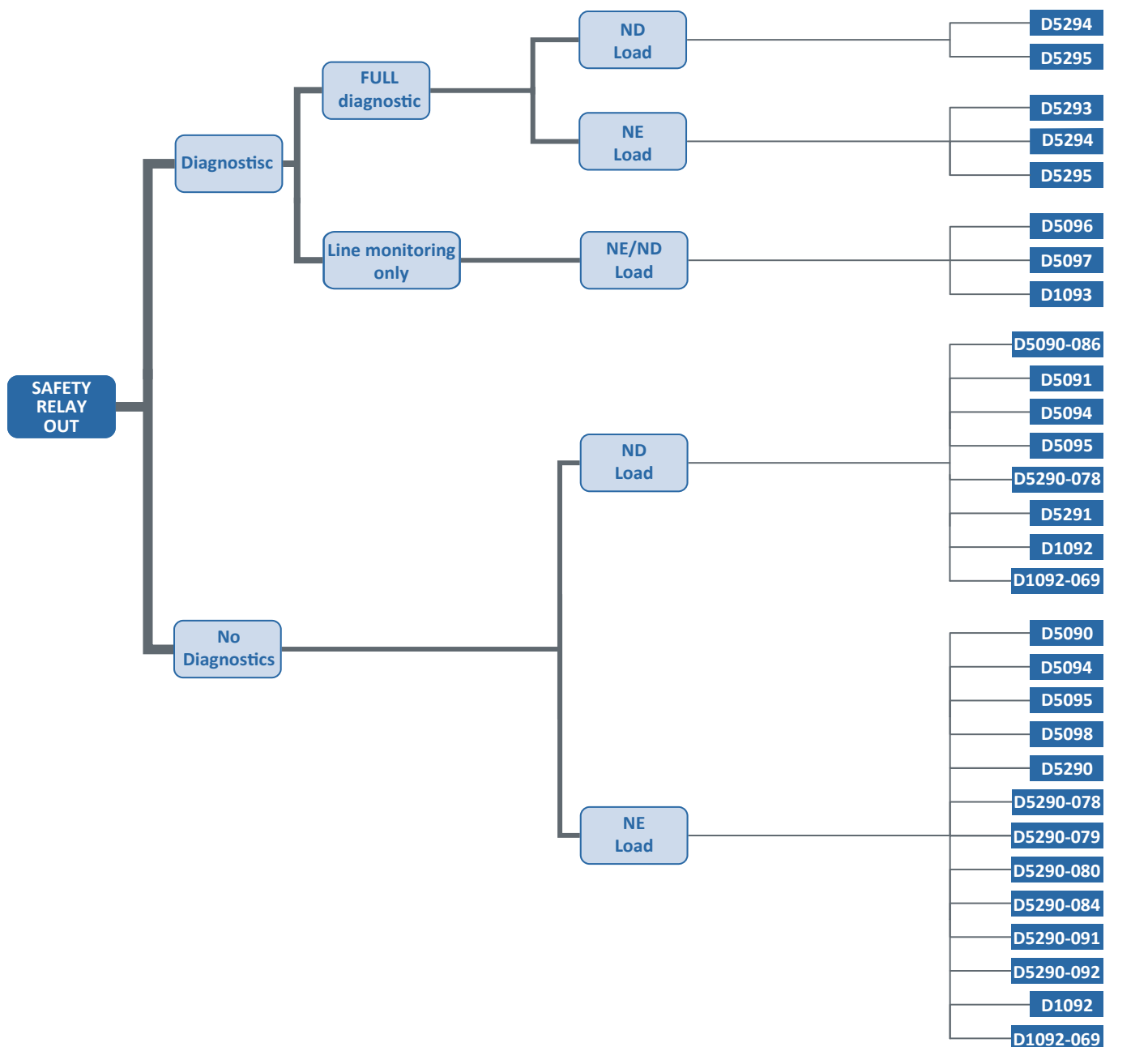
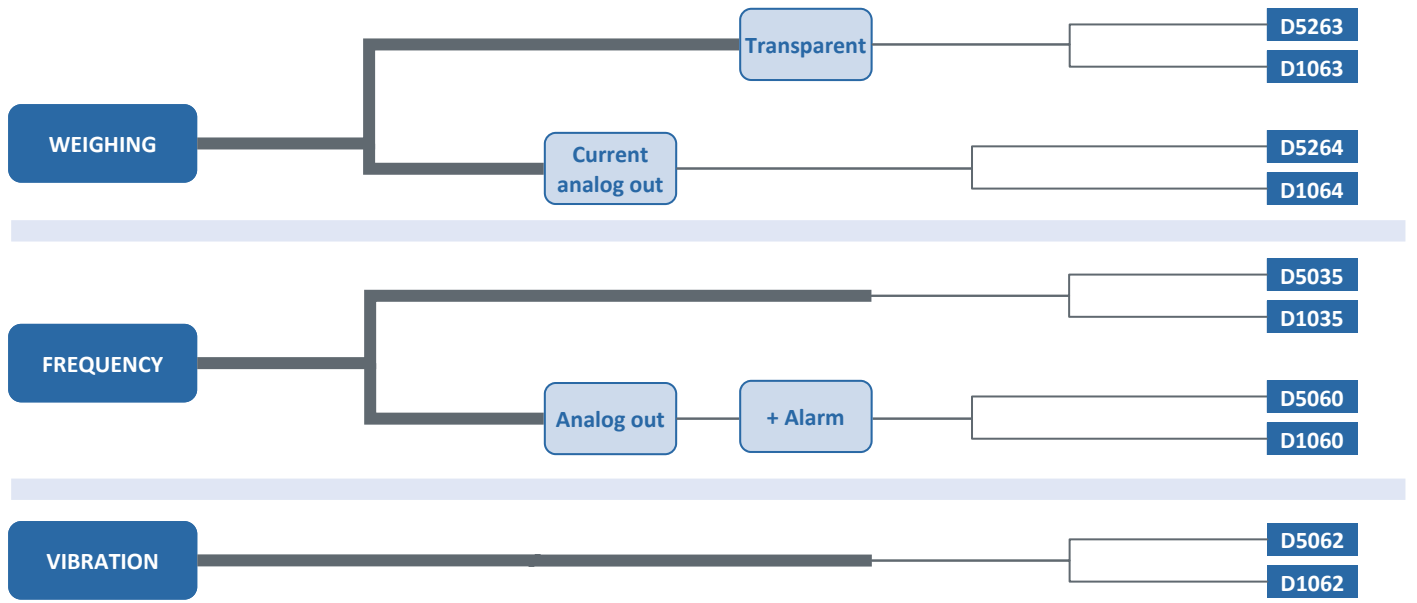





D5000 SERIES

ENHANCED INTRINSICALLY SAFE ISOLATORS
SUITABLE FOR SIL 2 AND SIL 3 APPLICATIONS



D5000 CHARACTERISTICS



D5200 DIMENSIONS

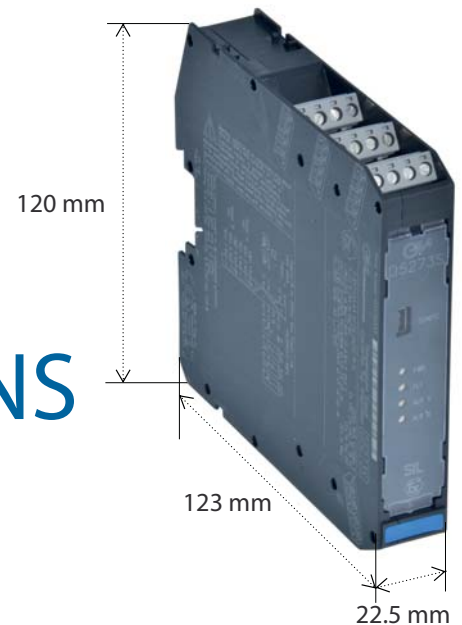

High Performance

- High signal transfer accuracy and repeatability
- Advanced circuitry provides very low heat dissipation, ensuring modules run cool despite their high density and functionality
- SMD manufacturing for a long, reliable life
- Complete absence of electrolytic capacitors ensures minimum 20 years lifetime

Wide Functionality

- Wide range of digital and analog I/O
- SIL 3 Safety Relay contacts rated for 4 A or 10 A for direct switching of high loads
- Three port galvanic isolation to eliminate noise, ground loop problems and to provide Intrinsic Safety without a high integrity safety earth connection
- Line fault alarm detects open or short circuit of field cables
- Optional power bus DIN-Rail connector
- Standard Termination Board with custom connectors for integration into customized Boards
- EMC Compatibility to EN61000-6-2, EN61000-6-4, EN61326-1, EN61326-3-1 for safety system

High Packing Density

- High packing density
- 35 mm (Top Hat) DIN-Rail
- Ultra slim 2 channels 12 mm wide DIN-Rail and Termination Board mounting modules
- Power and fault on bus connectors
- 6 mm per channel means 50% space reduction
- 3 mm per channel on DI module D5231E

General Features

- More than 25 modules suitable for SIL 3 applications according to IEC61508, IEC61511
- Independent power supply circuits for each channel on most modules
- Dual channel units are equivalent to two single units because of the absence of common circuitry on most modules
- Single channel versions available when required, to provide single loop integrity
- Configuration components are easily accessed by removing the side cover or via connector front panel
- DIP switch configurability for easy field setup
- LED indication for power, signal status and line fault conditions
- Modules accept DC power supply over a wide range for 24 Vdc (18-30 Vdc) applications
- Wide operating temp. range: -40 to +60/+70 °C
- Installation in Zone 2 / Division 2
- Certified for Offshore and Maritime applications



FEATURES

Blue Terminal Blocks
for Hazardous Area
connections

Grey Terminal Blocks
for Safe Area
connections

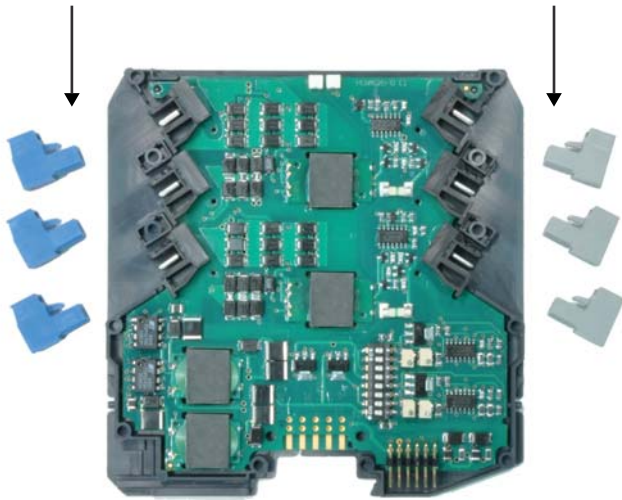

Enclosure Characteristics

- High channel density result from innovative circuit design using advanced surface mount components
- Plug-in screw terminal blocks to secure termination up to 2.5 mm²
- Configuration components are easily accessed by removing side cover

Detachable Cover for
direct access to
configuration components

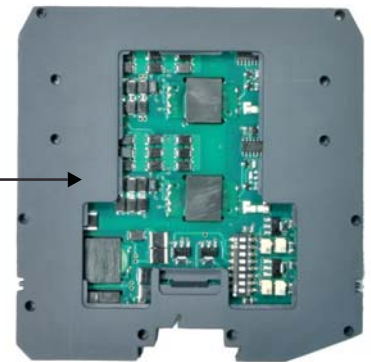

Enhanced Power Bus mounting

24 Vdc Power Supply Voltage can be applied to the module by directly connecting to the plug-in Terminal Block of each module, or via the Power Bus System.

The system consists of standard DIN-Rail modules mounted on DIN-Rail Bus connectors.

The maximum allowed powering capacity per trunk is 8 A. It is always possible to remove modules, without disconnecting the bus connector which remains attached to the DIN-Rail.

Communication bus is provided, on suitable models, to transmit via Modbus to DCS PLC logic solver to read input variables, diagnostic conditions, etc.

Cumulative Fault Alarm indication is provided on the Bus connection. This signal can be fed to a common unit (D5202S) which provides SPST Relay contact for common faults.

Both supply voltages are independently monitored and over or under condition are signaled via SPST Relay contact for power good (supply within operating range).

D5202S is also capable of operating as a redundant 4 A supply module for the system.



Bus plug-in connector



Bus connector terminal



DIN Rail stopper

TERMINATION BOARDS

Characteristics

- Suitable to host 8/16/32 D5000 or D5200 SIL 3 modules 12.5mm/22.5mm wide, single or double channel, for up to a total of 32 channels
- AI - AO - DI - DO Temperature: single or double channels
- Signal converter, Safety Relay: single channel
- 24Vdc redundant power supply, with window voltage monitoring and corresponding relay fault output
- Boards are available with custom connectors to directly interface any system PLC / DCS / ESD
- Cumulative fault relay output

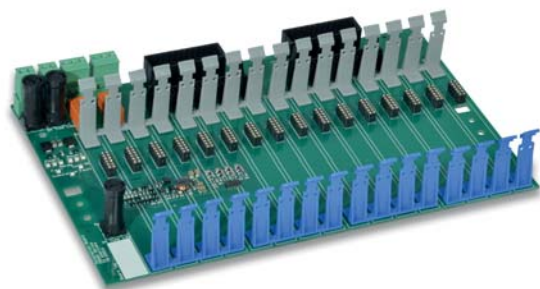
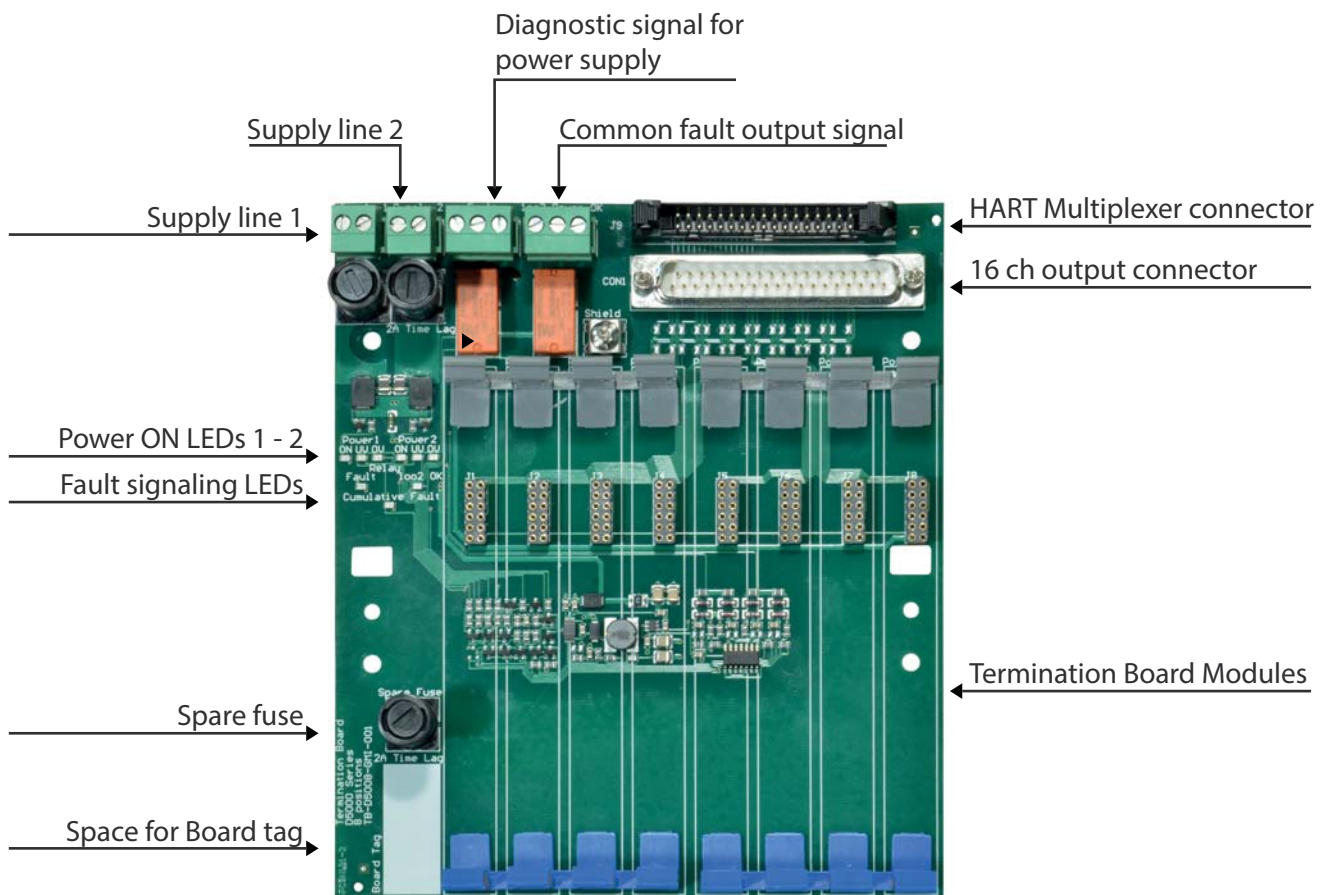

CONFIGURATION

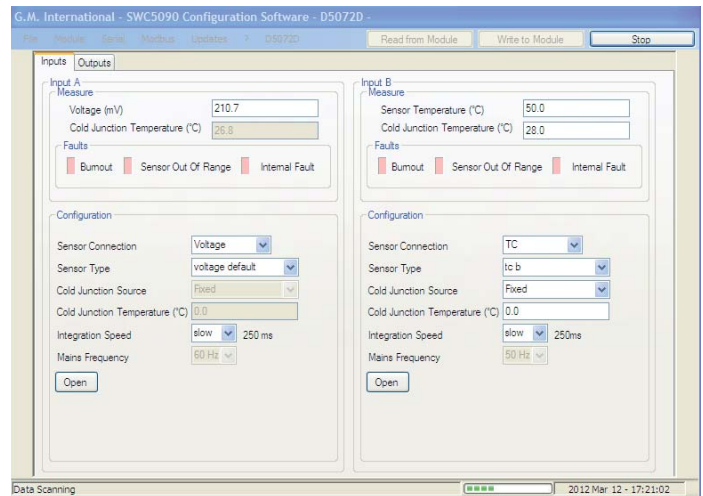
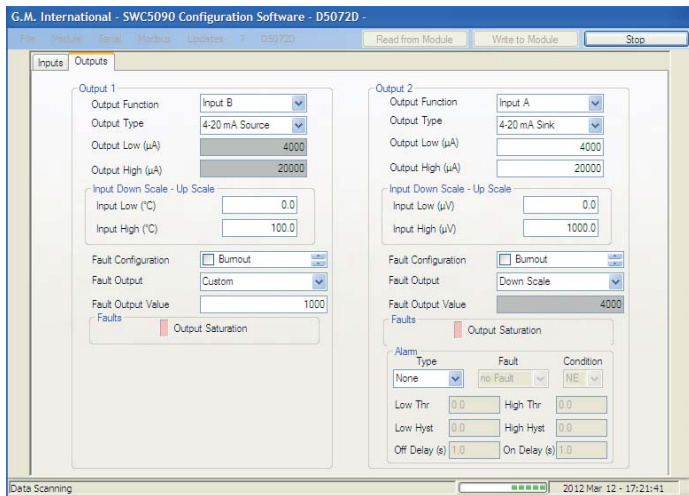

SWC5090 Software

SWC5090 software is designed to provide a PC user interface to configure suitable D5000, D5200 modules, via PPC5092 adapter.

It easily allows the user to:

- Read and write configuration parameters to the unit
- Store and restore data to and from local hard drive for backup or archive
- Load factory default configurations
- Monitor real time Input values for debug or test
- Print a report sheet containing configuration parameters and additional information

SWC5090 is freely distributed at our website: www.gmintsr.com



PPC5092 USB Adapter

PPC5092 interface allows the configuration of D5000, D5200 modules via SWC5090 software. Modules are supplied via USB for programming and therefore do not need any external power supply. Power Supply is requested for input monitoring or analog output check.

PPC5092 comes with mini-USB dedicated cable and CD-Rom containing SWC5090 software.

| Field device | Model | Hazardous Area | Safe Area | Ch. per unit | Supply | SIL level | | | | |
|--------------|----------------|------------------------------------------------------------------------|--------------------------------------------------|-------------------|------------------------------------------------------|--------------|-----------------------------------------------------------------|---|--------|--------------|
| ANALOG IN | D5011S | 4-20 mA 2-Wires Passive Tx Smart compatible | 4-20 mA (source) | 1 | 24 Vdc | SIL 3 | | | | |
| | D5011D | | | 2 | | SIL 3 | | | | |
| | D5014S | 4-20 mA 2-Wires Passive Tx 4-Wires Active Tx Smart compatible | 4-20 mA (source or sink) + 1-5 V (not SIL) | 1 | 24 Vdc | SIL 3 | | | | |
| | D5014D | | | 2 | | SIL 3 | | | | |
| | D5014D | | | 1 in 2 out | | SIL 3 | | | | |
| | D5015SS | 4-20 mA 2-Wires Passive Tx 4-Wires Active Tx Smart compatible | 4-20 mA (source) | 4-20 mA (sink) | 1 | 24 Vdc | SIL 2 | | | |
| | D5015SK | | | | 1 | | SIL 2 | | | |
| | D5015DS | | | | 2 | | SIL 2 | | | |
| | D5015DK | | | | 2 | | SIL 2 | | | |
| | D5015DS | | | | 1 in 2 out | | SIL 2 | | | |
| | D5015DK | | | | 1 in 2 out | | SIL 2 | | | |
| | D5212Q | | | | 0/4-20 mA 2-Wires Passive Tx 4-Wires Active Tx | | 0/4-20 mA (source) + I/O mapping + Modbus | 4 | 24 Vdc | SIL 2 |
| | D5254S | | | | 0/4-20 mA 2-Wires Passive Tx 4-Wires Active Tx | | 0/4-20 mA (sink/source) + 2 SPDT Trip amplifiers + Modbus | 1 | 24 Vdc | SIL 2 |

| | Field device | Model | Hazardous Area | Safe Area | Ch. per unit | Supply | SIL level |
|--------------------------------------------|--------------|-------------------|--------------------------------------------------------------------------------------------------|-----------------------------------------------------------------------------|---------------|--------|------------------------------------|
| TEMPERATURE CONVERTERS AND TRIP AMPLIFIERS | | D5072S | Universal TC, 3/4-Wires RTD, Potentiometer, mV | 4-20 mA (source or sink) Indep. set point via Solid State Relay + Modbus | 1 | 24 Vdc | SIL 2 |
| | | D5072D | Universal TC, 3-Wires RTD, Potentiometer, mV | 4-20 mA (source or sink) + Modbus Duplicator | 1 in 2 out | 24 Vdc | SIL 2 |
| | | D5072D | | 4-20 mA (source or sink) + Modbus | 2 | | SIL 2 |
| | | D5072S-087 | 2/3/4-Wires RTD | 2/3/4-Wires RTD | 1 | 24 Vdc | SIL 2 |
| | | D5273S | Universal TC, 3/4-Wires RTD, Pot, mV | 4-20 mA (source or sink) Indep. set points via SPDT Relay each + Modbus | | 24 Vdc | SIL 2 |
| ANALOG OUT | | D5020S | 4-20 mA Analog Signal to I/P Converters, Electrovalves, Actuators and Displays; Smart compatible | 4-20 mA Bus powered signal from DCS, PLC or other control devices. | 1 | 24 Vdc | SIL 2 |
| | | D5020D | | Two duplicated outputs. | 2 | | SIL 2 |
| DIGITAL OUTPUT DRIVER | | D5040S | NE solenoid valve, other control devices. | Loop Powered control signal from safety PLC, DCS | 1 | Loop | SIL 3 |
| | | D5040D | | | 2 | | SIL 3 |
| | | D5048S | NE solenoid valve, other control devices. Line open/short fault detection reflected on PLC. | Loop Powered control signal from safety PLC, DCS | 1 | Loop | SIL 3 |
| | | D5049S | | Logic level control signal from safety PLC, DCS | 1 | 24 Vdc | SIL 3 |
| | | D5240T | NE solenoid valve, other control devices. | Control signal from safety PLC, DCS + Modbus | 3 | 24 Vdc | SIL 2 |
| | | D5244S | SPDT (relay contact) | Voltage free Contact, Logic Level, | 1 | 24 Vdc | SIL 2 Independ. channels |
| | | D5244D | | Loop powered 24 Vdc from DCS, PLC or other control devices | 2 | | SIL 3 1002 channels |

| | Field device | Model | Hazardous Area | Safe Area | Ch. per unit | Supply | SIL level |
|------------|--------------|---------------|--------------------------------------------------------------------------------------|---------------------------------------------------------------------------------|---------------|-----------|--------------|
| DIGITAL IN | | D5030S | | SPDT (relay contact) + LED (fault status) | 1 | | SIL 3 |
| | | D5030D | Voltage free Contact, Proximity Switch Line fault detection Isolated inputs | SPST (relay contact) + SPST (alarm or duplicator) + LED (fault status) | 1 in 2 out | 24 Vdc | SIL 3 |
| | | D5030D | | SPST (relay contact) + LED (fault status) | 2 | | SIL 3 |
| | | D5031S | | Open Collector + LED (fault status) | 1 | | SIL 3 |
| | | D5031D | Voltage free Contact, Proximity Switch Line fault detection Isolated inputs | Open Collector + O.C. (alarm duplicator) + LED (fault status) | 1 in 2 out | 24 Vdc | SIL 3 |
| | | D5031D | | Open Collector + LED (fault status) | 2 | | SIL 3 |
| | | D5231E | Voltage free Contact, Proximity Switch Line fault detection | Open Collectors + LED (fault status) + Modbus | 8 | 24 Vdc | SIL 2 |
| | | D5032S | Voltage free Contact, Proximity Switch Line fault detection Isolated inputs | SPDT (relay contact) + LED (fault status) | 1 | 24 Vdc | SIL 3 |
| | | D5032D | Voltage free Contact, Proximity Switch Line fault detection Isolated inputs | SPST (relay contact) + SPST (alarm or duplicator) + LED (fault status) | 1 in 2 out | 24 Vdc | SIL 3 |
| | | D5032D | | SPST (relay contact) + LED (fault status) | 2 | | SIL 3 |
| | | D5034S | Voltage free Contact, Proximity Switch Isolated inputs | Transparent repeater of input status | 1 | 24 Vdc | SIL 3 |
| | | D5034D | | 0 to 8 mA range | 2 | | SIL 3 |

| | Field device | Model | Hazardous Area | Safe Area | Ch. per unit | Supply | SIL level |
|---------------------------|--------------|-------------------------------------------------------------------------------|-------------------------------------------------------------------|------------------------------------------------------------------------------------------|--------------|--------|--------------|
| DIGITAL IN | | D5036S | Voltage free Contact, Proximity Switch | SPST (relay contact) | 1 | 24 Vdc | SIL 2 |
| | | D5036D | Line fault detection Isolated inputs | + LED (fault status) | 2 | | SIL 2 |
| | | D5037S | Voltage free Contact, Proximity Switch | SPST (relay contact) | 1 | 24 Vdc | SIL 2 |
| | | D5037D | Line fault detection Isolated inputs | + LED (fault status) | 2 | | SIL 2 |
| SIGNAL CONVERTERS | | D5060S | 0-50 KHz Magnetic Pickup or Proximity Switch | mA (source), Pulse repeater Output | 1 | 24 Vdc | SIL 2 |
| | | D5254S | 4-20 mA / 0-20 mA 2/4 wires Tx 0.3 V to ± 30 V | 4-20 mA / 0-20 mA (source/sink) + 2 independent alarms via SPDT relays + Modbus | 1 | 24 Vdc | SIL 2 |
| VIBRATION INTERFACE | | D5062S | Vibration Transducers, Accelerometers, 2/3-Wires sensors | Transparent input repeater | 1 | 24 Vdc | SIL 2 |
| LOAD CELLS ISOLATOR CONV. | | D5264S | Up to 4, 350 Ω, 6-Wires Load Cells in parallel. | mA (source/sink) Output and Modbus RTU | 1 | 24 Vdc | SIL 2 |
| | | D5263S | | Transparent input repeater | 1 | | - |
| VARIOUS | | D5202S | | Power Distribution and Diagnostic Module | 1 | 24 Vdc | SIL 3 |
| POWER SUPPLIES | | for more information and details about Power Supplies, see section at page 75 | | | | | |
| SAFETY RELAYS | | for more information and details about Safety Relays, see section at page 33 | | | | | |

| Image | Code | Description |
|-------------------------------------------------------------------------------------|----------------|-----------------------------------------------------------------------------------------------------------------------|
|  | JDFT049 | 12 mm Power Bus Connector for DIN Rail Mounting. 1 needed for each BUS Module. |
|  | JDFT050 | 22 mm Power Bus Connector for DIN Rail Mounting. 1 needed for each BUS Module. |
|  | MCHP196 | Bus End Stopper. One needed for each end of Bus. |
|  | MOR015 | Plug-in terminal block male, vertical out, for Power Bus. |
|  | MOR017 | Plug-in terminal block male, horizontal out, for Power Bus. |
|  | MOR022 | Plug-in terminal block female, horizontal out, for Power Bus. |
|  | OPT5096 | Kit for Bus Mounting. Includes: 1 x MOR017, 1 x MOR022, 2 x MCHP196. |
|  | PPC5092 | PC Adapter required to configure programmable units; Mini USB Male cable to USB Port. |
|  | SWC5090 | PC Software for Configuration. Freely downloadable from www.gmint srl.com . |



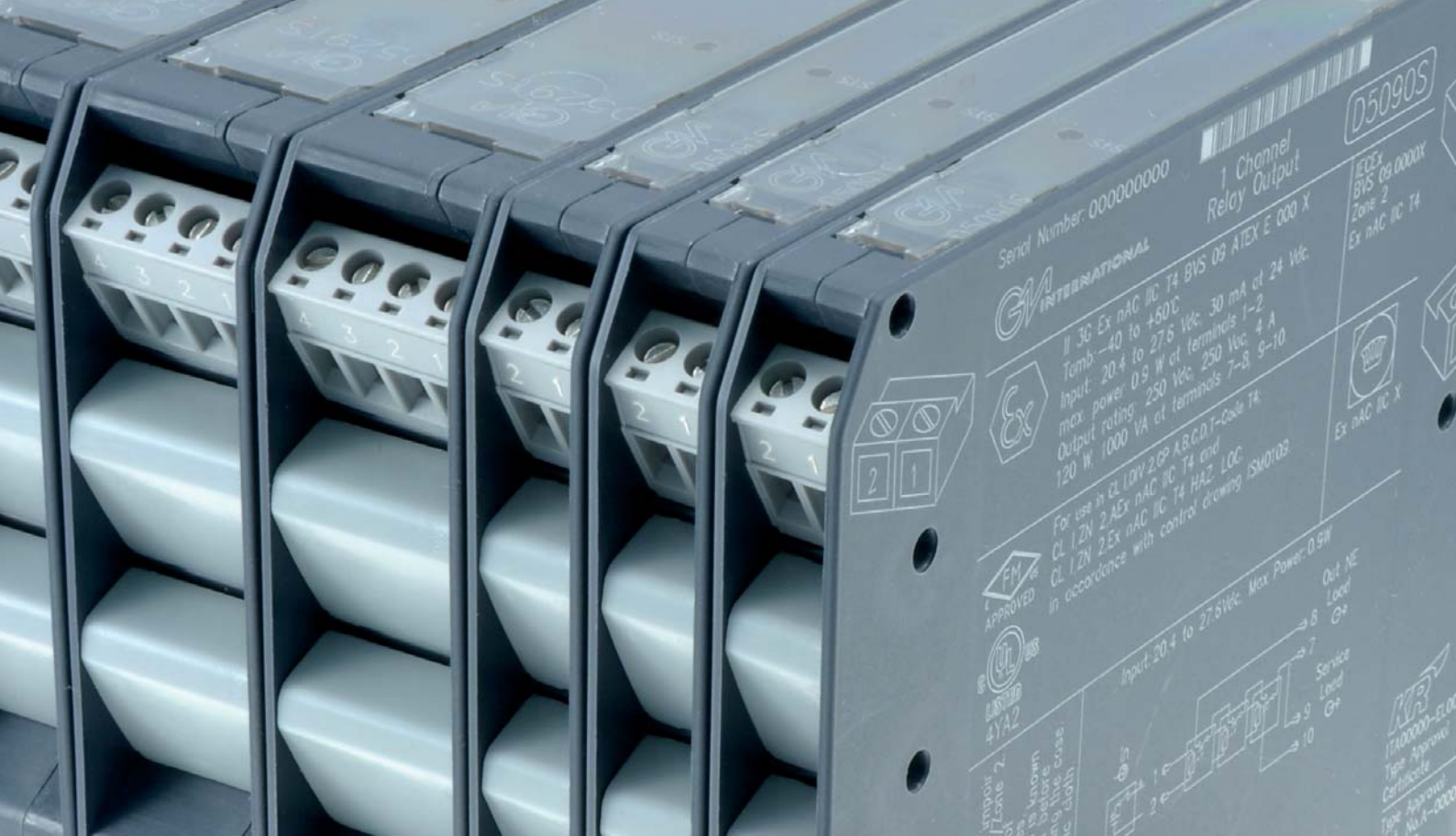

SAFETY RELAYS

HIGH INTEGRITY SAFETY RELAYS
SUITABLE FOR SIL 3 APPLICATIONS ACCORDING TO IEC61508



SAFETY RELAYS

CHARACTERISTICS

Introduction

When a load cannot be driven directly by a safety controller, an interposing relay becomes a requirement. For example, if the controller cannot handle the amount of power required to switch the load; or the voltage is different from 24 Vdc; or multiple contacts are required to be driven by the same control signal.

SIL certified safety relays are a requirement to meet the necessary Risk Reduction Factor (RRF) when switching a load ON or OFF, in an IEC61508/61511 Safety Instrumented Function (SIF). SIL certified relays guarantee that the safety function is met with a suitable and known probability of failure (PFD).

The market for SIL certified relays is growing very fast in all fields and applications and is no longer an exclusivity of the Oil & Gas sector, thanks to the increased implementation of functional safety standards. Controls and braking systems for trains are an example.



Safety Function

In order to properly select a SIL relay, special attention must be given to the Safety Function (SF) of the SIF where the SIL relay will be used, since different relay matrixes are used to achieve the required Safety Integrity Level.

The two most typical SFs are De-Energize to Trip (DTS) and Energize to Trip (ETS), however, combinations of the two are also possible.

DTS:

Used mostly in ESD systems to disconnect power to safety valves which are Normally Energized; it is achieved by removing power to the load through the opening of the DO signal (0 Volts or "0") and the consequential opening of the relay contacts.

ETS:

Used mostly in F&G systems to energize deluge valves which are Normally De-Energized or dormant; it is achieved by providing power to the load through the closing of the DO signal (24 Volts or "1") and the consequential closing of the relay contacts.

Combinations:

Sometimes the relay function must be inverted to achieve the required SF. Meaning that the control signal is 1 but the load must be 0, or vice versa.

Applications

Some of the most common applications for a SIL 2 or SIL 3 relay are the controlling of:

- Solenoid Valves (SOV) in ESD and F&G systems
- Beacons, Horns, and similar signaling devices
- Burner Management Systems (BMS)
- AC or DC Motors

SIL certified relays are also used for feedback signals and as interposing relays between different systems.

Relay Functions

There are four kinds of SIL relay functions defined by the status of the relay coil and the relay contacts in normal working conditions; not during a Safety Demand (SD).

- 1. Energized Coil (1) - Closed Contacts (1):**
Load Normally Energized; DTS Safety Function.
- 2. De-Energized Coil (0) - Open Contacts (0):**
Load Normally De-Energized; ETS Safety Function.
- 3. Energized Coil (1) - Open Contacts (0):**
Load Normally De-Energized; DTS Safety Function.
- 4. De-Energized Coil (0) - Closed Contacts (1):**
Load Normally Energized; ETS Safety Function.

Energized Relay Coil means a 1 High condition (power ON) at the relay coil terminals; De-Energized Relay Coil means the opposite, a 0 Low condition (power OFF) at the relay coil terminals.

Closed or Open Relay Contacts determine if power is available to the load under normal operating conditions: when contacts are closed the load is powered (NE) and when contacts are open the load is not powered (ND).

The Safety Function consists in reverting normal operating conditions.

For example, when the relay coil is energized and contacts are closed, the load is Normally Energized and the Safety Function is met when power is removed from the load; from High to Low condition.

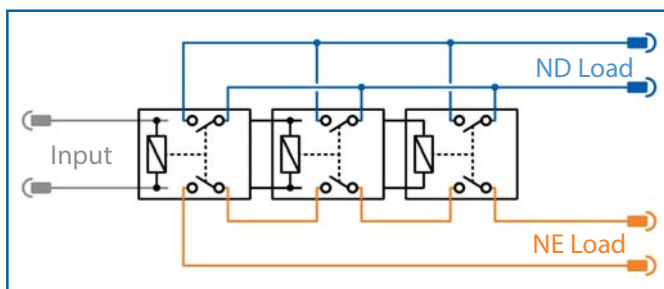

SAFETY RELAY BASIC OPERATIVE PRINCIPLES
Three relays in series for safety disconnection of NE Loads.
Three relays in parallel for safety connection of ND Loads.



D5294S

Coil Voltage

SIL certified relays are available with a variety of coil voltages either in DC or AC. The correct one should be chosen to match the coil driving signal.

Contact Form

The contact form and state of the relay output (NO/NC) should be determined by the SF; however, most of the time the SF is not known or not clearly specified. Additionally, the load can be interfaced by interrupting a single wire (+ or -) or both wires (+ and -).

Many solutions are available and in some cases multiple outputs are made available in a single SIL relay for a field configurable solution.

However a load can often be driven with a single relay.

Contact Rating

Once the correct Safety Function is chosen, the relay contacts rating for both AC and DC loads must be taken into consideration.

Maximum contact rating of the SIL certified relay should not be exceeded to retain the certified SIL level. Special care must be given to Inductive (overvoltage) or Capacitive (in-rush current) loads.

SIL relays are typically de-rated and capable of withstanding in-rush current or overvoltage spikes, but the normal working conditions must be below maximum specified to maintain the required SIL level. Some additional effort is required for DC loads since relay specification can be quite confusing.

For example GMI D5290S SIL 3 relay DC Rating is: 10 A / 250 Vdc / 300 W.

However, 10 x 250 is equal to 2.500 W and not 300 W! The difference is that the relay can either handle 250 Vdc or 10 A and not the combination of the two. The DC load graph provided in the Data Sheet must be used to verify the maximum allowed Load in various DC voltage levels. As shown here:

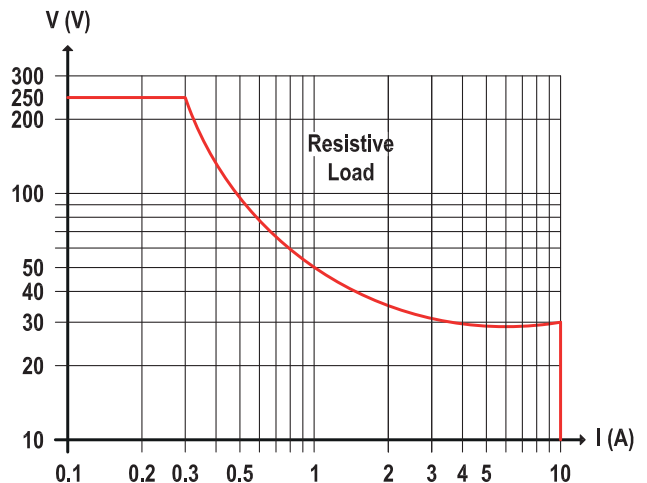

Line & Load Monitoring

SIL certified relays are used in SIFs which are always critical loops and careful consideration should be given to the requirement of Line and Load Monitoring. If it is true that in a DTS SF a wire or a coil failure will lead to safety, the same cannot be said of an ETS SF where a failure would lead to a dangerous condition which, if undetected, would lead to an unsafe status and consequential loss of SIL level. Some useful applications for Line Monitoring in DTS SFs are also possible; for example, monitoring the status of the coil to prevent spurious trips or to verify the condition of the individual coil in a redundant coil SOV. Line monitoring is also useful in Normally De-Energized systems such as F&G where it is not possible to perform line monitoring through conventional methods. When Line & Load Monitoring is required, three separate considerations must be made:

Pulse Test Compatibility:

The majority of today's control systems such as ESD or F&G can generate a pulse (active or passive) to verify line integrity. Its length and frequency varies from system to system but, in all cases, it can negatively affect relay functionality! A relay is not designed to be pulsed and, depending on the pulse length, the relay can change status (spurious

trip) or its anchors can partially move degrading and shortening the life of the relay itself. If a pulse test is required, a SIL certified relay with a filtering circuit on the front-end should be used. GMI D5000 series are fully compatible to Line Monitoring pulses from all system manufacturers.

Extension of Line Monitoring through the SIL Relay:

Control system diagnostic capabilities are designed to perform line monitoring when no relay is interposed between the control system and the load. As soon as a relay is placed in the loop, the diagnostic function stops at the relay input circuit (coil). To perform full line monitoring a SIL relay with built-in diagnostic circuit is required. These relays are able to diagnose a failure in the field wiring and load providing an alarm to the control system or other dedicated alarm channels.

Line Monitoring Functions:

A SIL relay with built-in diagnostics can perform two basic types of line monitoring: detection of open circuit and/or short circuit; both will lead to an unsafe condition for a Normally De-Energized SIF and can lead to a spurious trip in a Normally Energized SIF. Monitoring of the supply line should also be taken into consideration since loss of power leads to unsafe condition in an ETS SF.

Application Example

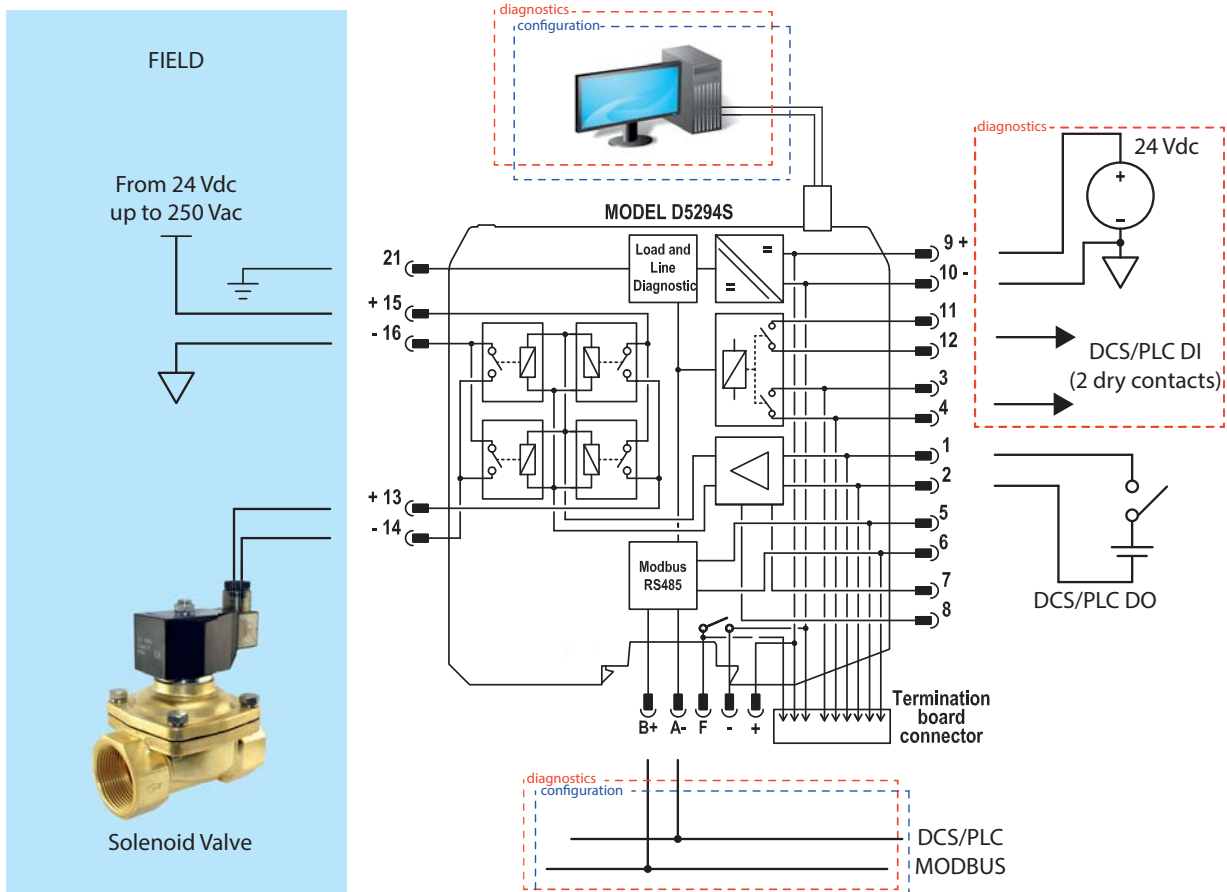

| Field device | Model | Application Examples (Figures show Normal Operation) | Rating | Features |
|------------------------------------------------------------------------------------------------------------------------------------------------------------------------------------------------------------------|----------------------------------------------------------------------------------------------------------------------|--------------------------------------------------------------------------------|--------------------------------------------------------------------------------|----------|
| SAFETY RELAYS | D5090S | | 5 A 250 Vac 1250 VA 5 A 250 Vdc 140 W 24 Vdc Coil | |
| | Normal Operation: NE Relay Coil and NE Load (1-1). Safe State: Load is disconnected by disconnecting input (0-0). | | | |
| | D5090S-086 | | 5 A 250 Vac 1250 VA 5 A 250 Vdc 140 W 24 Vdc Coil | |
| | Normal Operation: ND Relay Coil and NE Load (0-1). Safe State: Load is disconnected by connecting input (1-0). | | | |
| | D5091S | | 5 A 250 Vac 1250 VA 5 A 250 Vdc 140 W 24 Vdc Coil | |
| Normal Operation: ND or NE Relay Coil and ND Load (0-0 or 1-0). Safe State: Load is connected by connecting input (1-1) or by disconnecting input (0-1). | | | | |
| D5094S | | 5 A 250 Vac 1250 VA 5 A 250 Vdc 140 W 24 Vdc Coil | | |
| Normal Operation: NE Relay Coil and NE Load (1-1) or ND Relay Coil and F&G/ND Load (0-0). Safe State: Load is disconnected by disconnecting input (0-0) or Load is connected by connecting input (1-1). | | | | |

| Field device | Model | Application Examples (Figures show Normal Operation) | Rating | Features |
|--------------|---------------|-----------------------------------------------------------------------------------------------------------------------------------------------------------------------------------------------------------------------------------------------------------------------|--------------------------------------------------------------------------------|----------|
| | D5095S | <p>Normal Operation: ND Relay Coil and NE Load (0-1) or NE Relay Coil and F&G/ND Load (1-0). Safe State: Load is disconnected by connecting input (1-0) or Load is connected by disconnecting input (0-1).</p> | 5 A 250 Vac 1250 VA 5 A 250 Vdc 140 W 24 Vdc Coil | |
| | D5096S | <p>Normal Operation: NE Relay Coil and NE Load (1-1) or ND Relay Coil and F&G/ND Load (0-0). Safe State: Load is disconnected by disconnecting input (0-0) or Load is connected by connecting input (1-1). Smart line and load diagnostics functions.</p> | 5 A 250 Vac 1250 VA 5 A 250 Vdc 140 W 24 Vdc Coil | |
| | D5097S | <p>Normal Operation: ND Relay Coil and NE Load (0-1) or NE Relay Coil and F&G/ND Load (1-0). Safe State: Load is disconnected by connecting input (1-0) or Load is connected by disconnecting input (0-1). Smart line and load diagnostic functions.</p> | 5 A 250 Vac 1250 VA 5 A 250 Vdc 140 W 24 Vdc Coil | |
| | D5098S | <p>Normal Operation: NE Relay Coil and NE Load (1-1). Safe State: Load is disconnected by disconnecting input (0-0).</p> | 5 A 250 Vac 1250 VA 5 A 250 Vdc 140 W 24 Vdc Coil | |

SAFETY RELAYS



| Field device | Model | Application Examples (Figures show Normal Operation) | Rating | Features |
|---------------|----------------|--------------------------------------------------------------------------------------------------------------------------------------------|----------------------------------------------------------------------------------|----------|
| SAFETY RELAYS | D5098D | <p>Normal Operation: Dual channel. NE Relay Coil and NE Load (1-1). Safe State: Load is disconnected by disconnecting input (0-0).</p> | 5 A 250 Vac 1250 VA 5 A 250 Vdc 140 W 24 Vdc Coil | |
| | D5290S | <p>Normal Operation: NE Relay Coil and NE Load (1-1). Safe State: Load is disconnected by disconnecting input (0-0).</p> | 10 A 250 Vac 2500 VA 10 A 250 Vdc 300 W 24 Vdc Coil | |
| | D5290S -078 | <p>NE or ND Relay Coil and NE-ND or ND Load for interrupting up to 4 loads. SIL 3 function: configurable via external wiring.</p> | 5 A 250 Vac 1250 VA 5 A 250 Vdc 175 W 24 Vdc Coil | |
| | D5290S -079 | <p>NE Relay Coil and NE or ND Load for interrupting up to 4 loads. AC Coil. SIL 3 function: configurable via external wiring.</p> | 5 A 250 Vac 1250 VA 5 A 250 Vdc 175 W 115 Vac Coil | |

| Field device | Model | Application Examples (Figures show Normal Operation) | Rating | Features |
|--------------|------------------------|-------------------------------------------------------------------------------------------------------------------------------|-----------------------------------------------------------------------------------|--------------|
| | D5290S -080 | | 10 A 250 Vac 2500 VA 10 A 250 Vdc 300 W 115 Vac Coil | SIL 3 |
| | | Normal Operation: NE Relay Coil and NE Load (1-1). AC Coil. Safe State: Load is disconnected by disconnecting input (0-0). | | |
| | D5290S -081 | | 10 A 250 Vac 2500 VA 10 A 250 Vdc 300 W 110 Vdc Coil | SIL 3 |
| | | Normal Operation: NE Relay Coil and NE Load (1-1). Safe State: Load is disconnected by disconnecting input (0-0). | | |
| | D5290S -084 | | 5 A 250 Vac 1250 VA 5 A 250 Vdc 175 W 110 Vdc Coil | SIL 3 |
| | | NE Relay Coil and NE or ND Load for interrupting up to 4 loads. AC Coil. SIL 3 function: configurable via external wiring. | | |
| | D5290S -091 | | 10 A 250 Vac 2500 VA 10 A 250 Vdc 300 W 230 Vac Coil | SIL 3 |
| | | Normal Operation: NE Relay Coil and NE Load (1-1). AC Coil. Safe State: Load is disconnected by disconnecting input (0-0). | | |

SAFETY RELAYS



| Field device | Model | Application Examples (Figures show Normal Operation) | Rating | Features |
|---------------|-------------------|-------------------------------------------------------------------------------------------------------------------------------------------------------------------------------------------------------------------------------------------------------------------------------------|----------------------------------------------------------------------------------|----------|
| SAFETY RELAYS | D5290S-092 | <p>Normal Operation: NE Relay Coil and NE Load (1-1). Safe State: Load is disconnected by disconnecting input (0-0).</p> | 10 A 250 Vac 2500 VA 10 A 250 Vdc 300 W 48 Vdc Coil | |
| | D5291S | <p>Normal Operation: ND or NE Relay Coil and ND Load (0-0 or 1-0). Safe State: Load is connected by connecting input (1-1) or by disconnecting input (0-1).</p> | 10 A 250 Vac 2500 VA 10 A 250 Vdc 300 W 24 Vdc Coil | |
| | D5293S | <p>Normal Operation: NE Relay Coil and NE Load (1-1). Safe State: Load is disconnected by disconnecting input (0-0). Smart line and load diagnostic functions. Modbus output.</p> | 4 A 250 Vac 1000 VA 4 A 250 Vdc 120 W 24 Vdc Coil | |
| | D5294S | <p>Normal Operation: ND Relay Coil and F&G/ND Load (0-0) or NE Relay Coil and NE Load (1-1). Safe State: Load is connected by connecting input (1-1) or Load is disconnected by disconnecting input (0-0). Smart line and load diagnostic functions. Modbus output.</p> | 4 A 250 Vac 1000 VA 4 A 250 Vdc 120 W 24 Vdc Coil | |

| Field device | Model | Application Examples (Figures show Normal Operation) | Rating | Features |
|--------------|-------------------|-----------------------------------------------------------------------------------------------------------------------------------------------------------------------------------------------------------------------------------------------------------------------------------------------------------|--------------------------------------------------------------------------------|------------------|
| | D5295S | <p>Normal Operation: ND Relay Coil and NE Load (0-1) or NE Relay Coil and F&G/ND Load (1-0). Safe State: Load is disconnected by connecting input (1-0) or Load is connected by disconnecting input (0-1). Smart line and load diagnostic functions. Modbus output.</p> | 4 A 250 Vac 1000 VA 4 A 250 Vdc 120 W 24 Vdc Coil | |
| | D1092S | <p>Normal Operation: NE Relay Coil and NE Load (1-1) or ND Relay Coil and ND Load (0-0). Safe State: Load is disconnected by disconnecting input (0-0) or Load is connected by connecting input (1-1).</p> | 3 A 250 Vac 750 VA 3 A 125 Vdc 120 W 24 Vdc Coil | |
| | D1092D | <p>Normal Operation: Dual channel. NE Relay Coil and NE Load (1-1) or ND Relay Coil and ND Load (0-0). Safe State: Load is disconnected by disconnecting input (0-0) or Load is connected by connecting input (1-1).</p> | 3 A 250 Vac 750 VA 3 A 125 Vdc 120 W 24 Vdc Coil | |
| | D1092S-069 | <p>Normal Operation: NE Relay Coil and NE Load (1-1) or ND Load (1-0). Safe State: Load is disconnected by disconnecting input (0-0) or Load is connected by disconnecting input (0-1).</p> | 3 A 250 Vac 750 VA 3 A 125 Vdc 120 W 24 Vdc Coil | |

SAFETY RELAYS



| Field device | Model | Application Examples (Figures show Normal Operation) | Rating | Features |
|---------------|-------------------|----------------------------------------------------------------------------------------------------------------------------------------------------------------------------------------------------------------------------------------------------------|-------------------------------------------------------------------------------|--------------|
| SAFETY RELAYS | D1092D-069 | <p>Normal Operation: Dual channel. NE Relay Coil and NE Load (1-1) or NE Relay Coil and ND Load (1-0). Safe State: Load is disconnected by disconnecting input (0-0) or Load is connected by disconnecting input (0-1).</p> | 3 A 250 Vac 750 VA 3 A 125 Vdc 120 W 24 Vdc Coil | SIL 3 |
| | D1093S | <p>Normal Operation: NE Relay Coil and NE Load (1-1) or ND Relay Coil and ND Load (0-0). Safe State: Load is disconnected by disconnecting input (0-0) or Load is connected by connecting input (1-1). Line and load diagnostic functions.</p> | 3 A 250 Vac 750 VA 3 A 125 Vdc 120 W 24 Vdc Coil | SIL 3 |
| | D5093S | <p>Normal Operation: Solid state NE Relay, configurable from 24 to 220 VAC/VDC input drive, 24 VDC rated voltage free output contact. Safe State: PLC input circuit is open when AC/DC input drive is removed. Input/Output isolation.</p> | 50 mA 35 Vdc | SIL 3 |
| | D5093D | <p>Normal Operation: Dual Solid state NE Relays, configurable from 24 to 220 VAC/VDC input drive, 24 VDC rated voltage free output contact. Safe State: PLC input circuit is open when AC/DC input drive is removed. Input/Output isolation.</p> | 50 mA 35 Vdc | SIL 3 |
| | | | | |



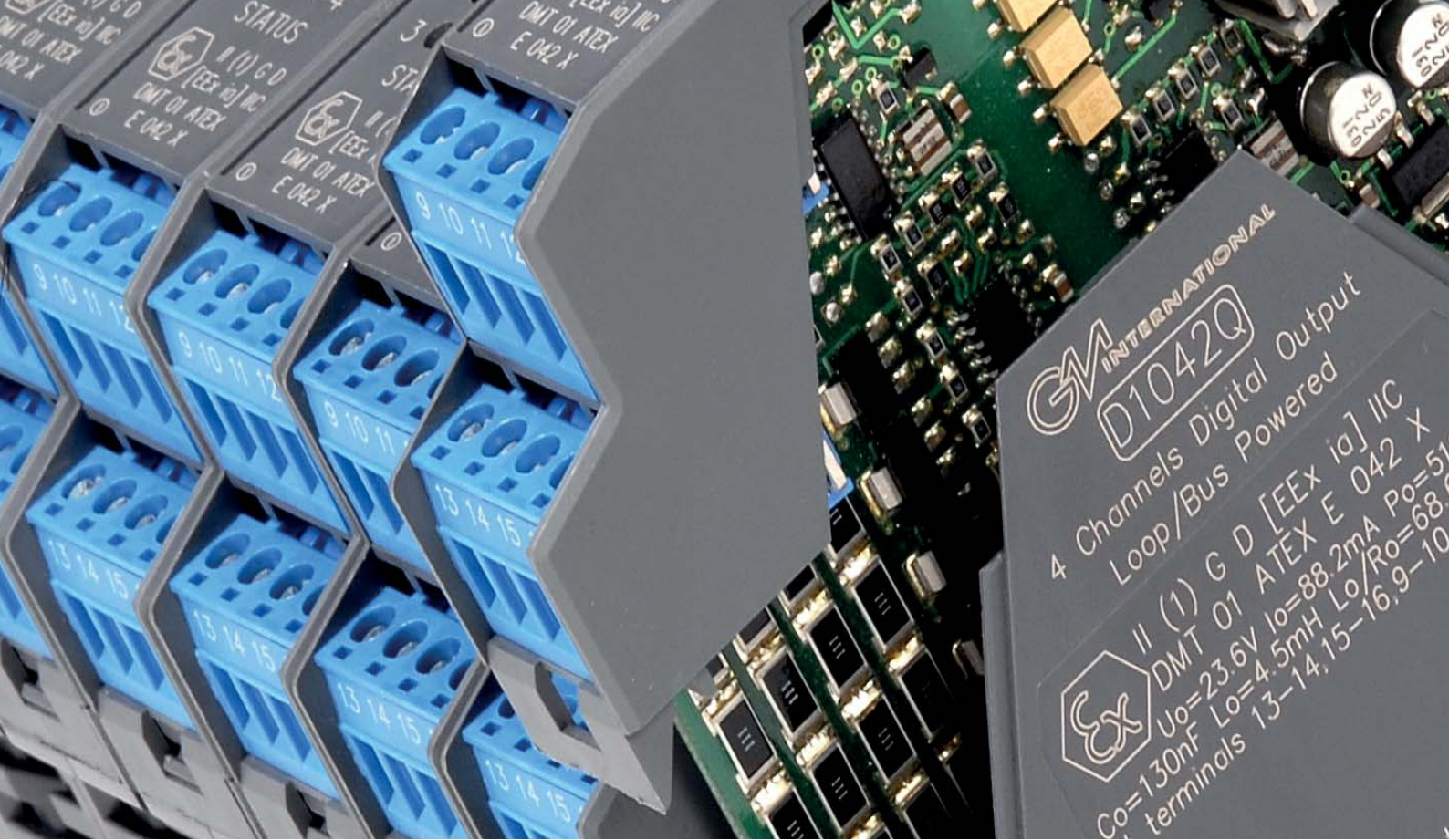

D1000 SERIES

INTRINSICALLY SAFE ISOLATORS
SUITABLE FOR SIL 2 AND SIL 3 APPLICATIONS

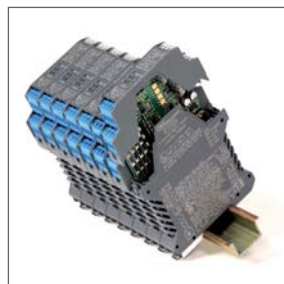

D1000

CHARACTERISTICS

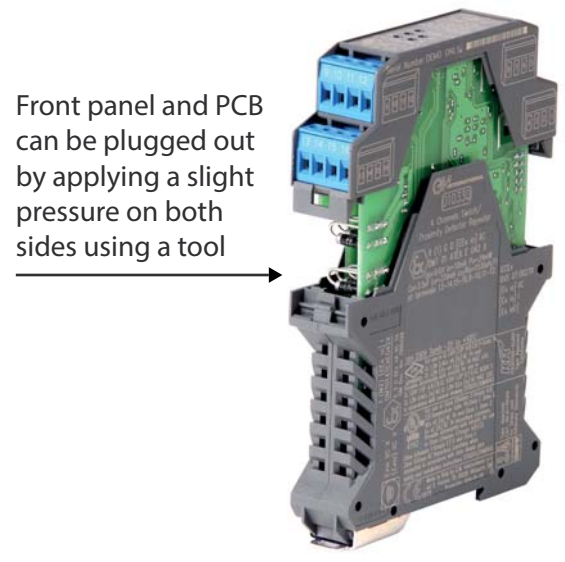
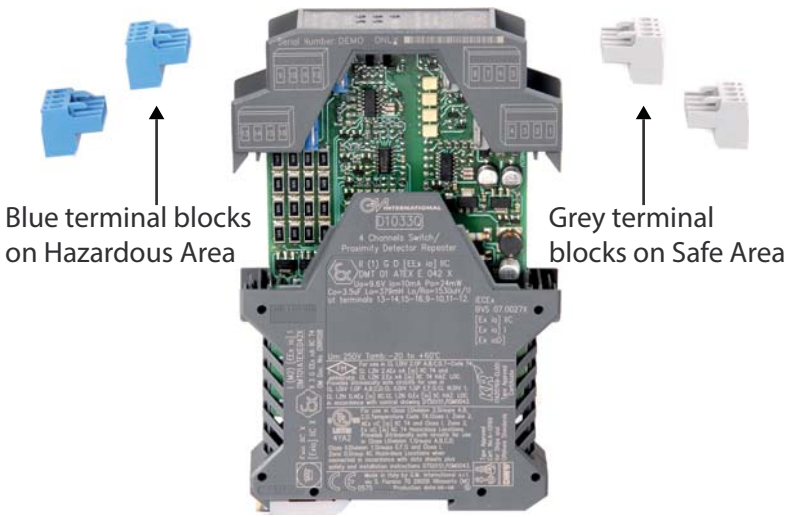
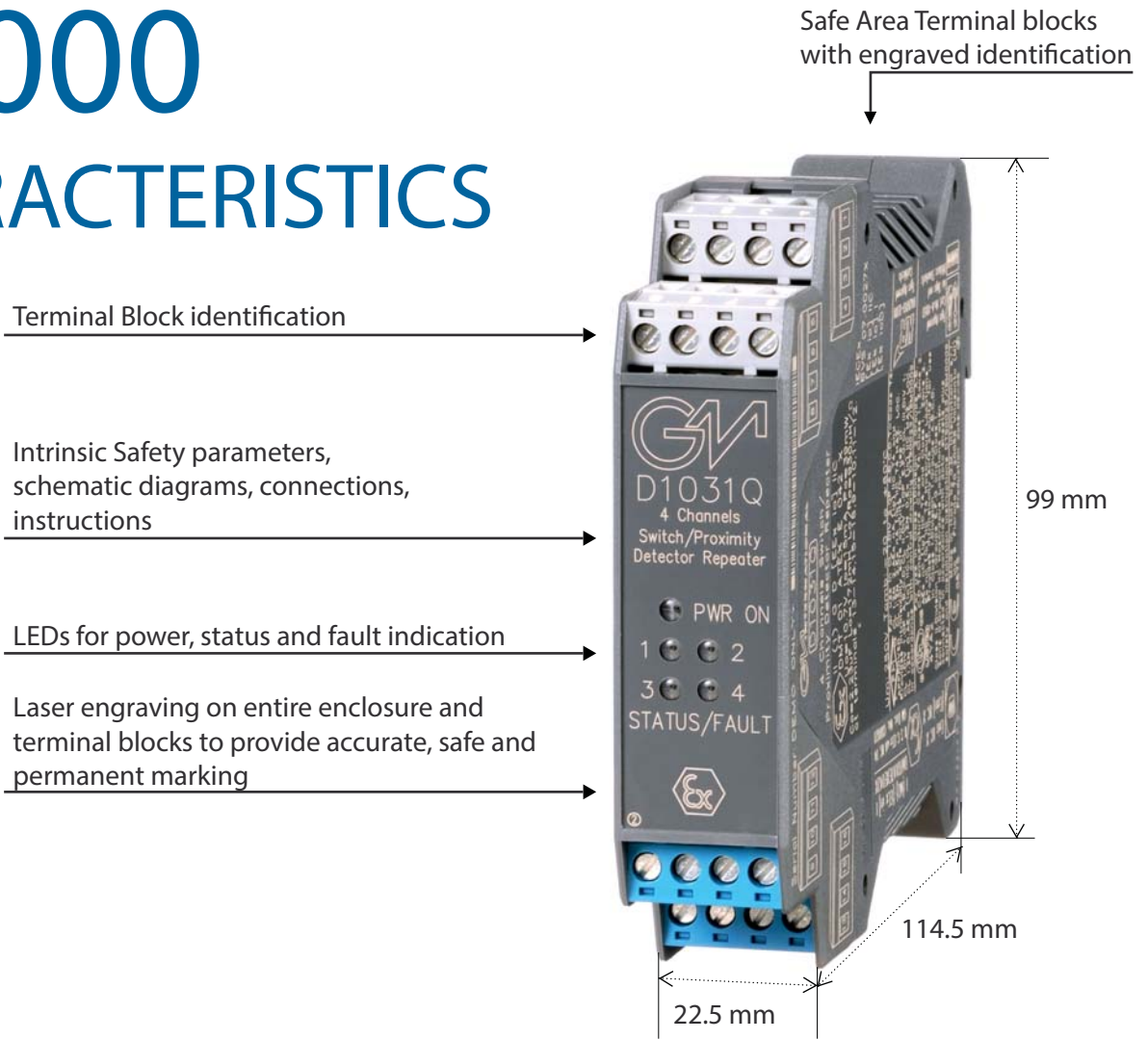

FEATURES

General Features

- More than 30 modules suitable for SIL 3 - SIL 2 applications according to IEC61508, IEC61511
- Single channel versions available if required, to provide single loop integrity on Emergency Shut Down and Fire & Gas applications
- Configuration via DIP switch for easy field setup
- LED indication for power, signal status and line fault conditions
- Modules accept DC power supply over a wide range for 12 or 24 Vdc applications
- 2 modules (D1130 - D1180) can be powered from 85 to 264 Vac, 50-400 Hz, or from 100 to 350 Vdc
- Wide operating temperature range (-20 / +60°C)

Enclosure Characteristics

- High channel density resulting from innovative circuit design using advanced surface mount components
- Single, dual or quad channel models
- Plug-in screw terminal blocks to secure terminations up to 2.5 mm²
- Plug-in PCB can be removed for configuration operations

High Performance

- High signal transfer accuracy and repeatability
- Advanced circuitry provides low heat dissipation, ensuring modules run cool despite their high functionality
- Low power consumption
- SMD manufacturing for a long and reliable life

Wide Functionality

- Wide range of Digital and Analog I/Os
- Relay contacts rated for 2 A to directly switch high loads
- Three port galvanic isolation to eliminate noise, ground loop problems and to provide Intrinsic Safety without a high integrity safety earth connection
- Line fault alarm detects open or short circuit of field cables
- Optional Power Bus enclosure

PACKING

High Packing Density

- 35 mm (Top Hat) DIN-Rail
- Ultra slim 4 channels 22.5 mm wide DIN-Rail mounting modules
- 6 mm per channel
- Up to 176 I/O channels per meter of DIN-Rail
- Power Bus enclosure allows a significant reduction in cables, costs and space

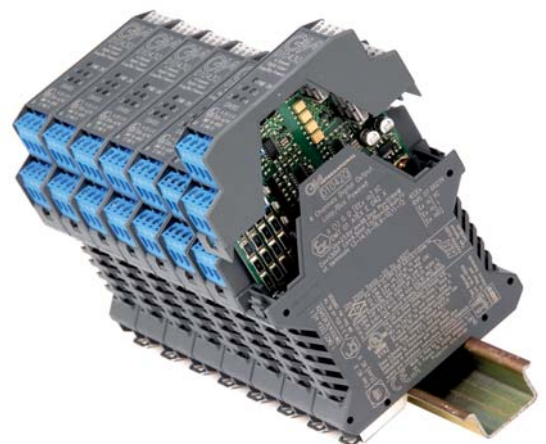

POWER BUS

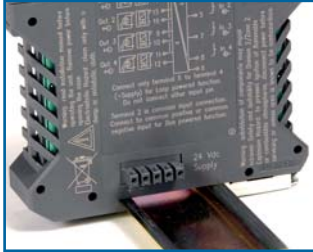

Power Bus Connector
Male Side



Power Bus Connector
Female Side



Module With Power Bus Male
Termination Block

Enhanced Power Bus Mounting

24 Vdc power supply voltage can be applied to the module, by connecting the voltage directly to the plug-in Terminal Block of each module, or via [Power Bus System](#).

The system consists of a standard Din-Rail Bar and modules with Bus Connectors (female on one side and male on the opposite side) of 8 A Capacity. It is always possible to remove modules, without disconnecting the connectors, because modules are plug-in types. Contacts on the Terminal Block are omitted to avoid accidental short circuits on the Power Bus.



TERMINATION BOARD

PBCO Series

G.M. International offers many solutions for Customized Boards for an easy integration with instrumentation of manufacturers like Invensys Foxboro, ABB, Triconex, Yokogawa, Honeywell, HIMA and many more.

New Board models are engineered on customer request for any system or application: contact us for details.

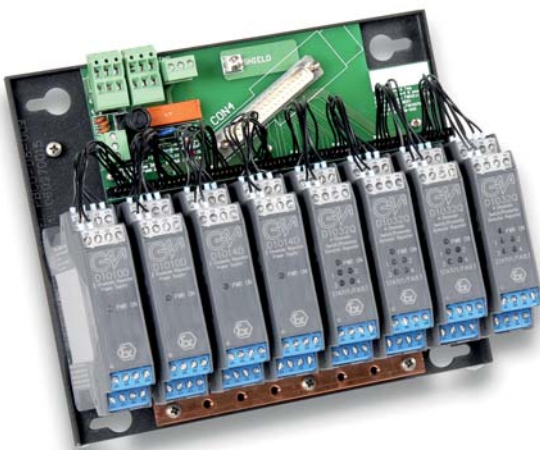

CONFIGURATION

PPC 1090 Pocket Portable Configurator

The PPC1090 is a small and handy Pocket Portable Configurator suitable to program configuration parameters of D1000 series modules like: type of input Sensors, input and output Ranges, Burnout conditions, High/Low Alarm mode, Relay NE/ND, Alarm Trip Point, Hysteresis value and ON/OFF Alarm delays.

The Configurator is powered by the unit and can be plugged in without disconnecting the module.

PPC 1092 Serial Adapter

The PPC1092 adapter is needed to interface the PC with D1000 Series modules for a complete configuration of Input, Output and Alarm parameters.

The package includes necessary cables and a USB to RS-232 Adapter; a CD-Rom with the SWC1090 Software is also provided.

The SWC1090 can also be downloaded from our website.

D1000 Modules which can be configured via PC are:

| | |
|-------|---------------------------------------------------------|
| D1052 | Analog Signal Converter, Duplicator, Adder, Subtractor |
| D1053 | Analog Signal Converter and Trip Amplifiers |
| D1054 | Repeater Power Supply and Trip Amplifiers |
| D1060 | Frequency-Pulse Converter, Repeater and Trip Amplifiers |
| D1064 | Load Cell/Strain Gauge Bridge Isolating Converter |
| D1072 | Temperature Signal Converter |
| D1073 | Temperature Signal Converter and Trip Amplifiers |

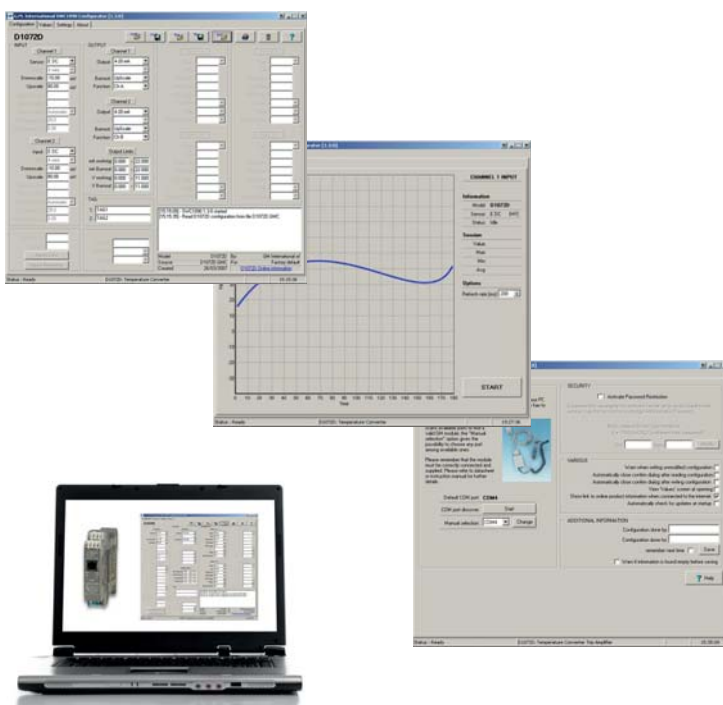

SWC1090 Software

The SWC1090 software is designed to provide a PC user interface to configure programmable D1000 modules.

It easily allows the user to:

- Read and write configuration parameters to the units
- Store and restore data to and from local hard drive for backup or archive
- Load factory default configurations
- Monitor Input values via USB/COM port
- Print a report sheet containing configuration parameters and additional information

The SWC1090 is freely downloadable from our website: www.gmintsr.com















| | Field device | Model | Hazardous Area | Safe Area | Ch. per unit | Supply | SIL level |
|---------------------|--------------|-------------------|----------------------------------------------------------------------------------------------|----------------------------------------------------------------------------------|---------------|--------------|--------------|
| ANALOG IN | | D1010S | | 4-20 mA 0-20 mA (source or sink) | 1 | 24 Vdc | SIL 2 |
| | | D1010D | 0/4-20 mA 2-Wires Passive Tx 4-Wires Active Tx Smart compatible | or 1-5 V 0-5 V | 2 | | SIL 2 |
| | | D1010D | | Two duplicated outputs | 1 in 2 out | | SIL 2 |
| | | D1010S-046 | 0/4-20 mA 2-Wires Passive Tx 4-Wires Active Tx Smart compatible. | 4-20 mA 0-20 mA (source or sink) or 1-5 V 0-5 V | 1 | 24 Vdc | SIL 2 |
| | | D1010D-046 | Certified with lower safety parameters | 1-5 V 0-5 V | 2 | | SIL 2 |
| | | D1012Q | 4-20 mA 2-Wires Passive Tx | 4-20 mA (source) | 4 | 24 Vdc | - |
| | | D1014S | 4-20 mA 2-Wires Passive Tx | 4-20 mA (source or sink) or 1-5 V | 1 | 12-24 Vdc | SIL 2 |
| | | D1014D | Smart compatible | | 2 | | SIL 2 |
| ANALOG OUT | | D1020S | 4-20 mA 0-20 mA Analog Signal to I/P Converters, Electrovalves, Actuators and Displays | 4-20 mA 0-20 mA Bus powered signal from DCS, PLC or other control devices. | 1 | 24 Vdc | SIL 2 |
| | | D1020D | Smart compatible | | 2 | | SIL 2 |
| FIRE & GAS DETECTOR | | D1022S | 1 to 40 mA Fire/Smoke Detector | 1 to 40 mA to DCS, PLC or other control devices | 1 | Loop powered | - |
| | | D1022D | | | 2 | | - |

| Field device | Model | Hazardous Area | Safe Area | Ch. per unit | Supply | SIL level | |
|--------------|-------|----------------|-------------------------------------------------------------|------------------------------------------------------------------------------|--------|-------------|--------------|
| DIGITAL IN | | D1030S | Voltage free Contact, | SPDT (relay contact) + SPDT (alarm or duplicator) + LED (fault status) | 1 | 24 Vdc | SIL 2 |
| | | D1030D | Proximity Switch Line fault detection | SPDT (relay contact) + LED (fault status) | 2 | | SIL 2 |
| | | D1130S | Voltage free Contact, | SPDT (relay contact) + SPDT (alarm or duplicator) + LED (fault status) | 1 | 110-230 Vac | SIL 2 |
| | | D1130D | Proximity Switch Line fault detection | SPDT (relay contact) + LED (fault status) | 2 | | SIL 2 |
| | | D1031D | Voltage free Contact, | Open Collectors + OC (alarm or duplicator) + LED (fault status) | 2 | 12-24 Vdc | SIL 2 |
| | | D1031Q | Proximity Switch Line fault detection | Open Collectors + LED (fault status) | 4 | | SIL 2 |
| | | D1032D | Voltage free Contact, | SPST (relay contact) + SPST (alarm or duplicator) + LED (fault status) | 2 | 24 Vdc | SIL 2 |
| | | D1032Q | Proximity Switch Line fault detection Isolated inputs | SPST (relay contact) + LED (fault status) | 4 | | SIL 2 |
| | | D1033D | Voltage free Contact, | Open Collectors + OC (alarm or duplicator) + LED (fault status) | 2 | 24 Vdc | SIL 2 |
| | | D1033Q | Proximity Switch Line fault detection Isolated inputs | 4 Open Collectors + LED (fault status) | 4 | | SIL 2 |
| | | D1034S | Voltage free Contact, | Transparent repeater of input status 0 to 8 mA range | 1 | 12-24 Vdc | SIL 3 |
| | | D1034D | Proximity Switch Line fault detection Isolated inputs | | 2 | | SIL 3 |
| | | D1035S | 0-50 KHz Magnetic Pickup or Proximity Switch | Voltage free SPST optocoupled OC transistor | 1 | 12-24 Vdc | - |

| | Field device | Model | Hazardous Area | Safe Area | Ch. per unit | Supply | SIL level | |
|-------------|--------------|---------------|------------------------------------------------------------------------------|---------------------------------------------------------------------------------------------------|--------------------------------------------------------------------|--------|------------------------------------|------------------------------|
| DIGITAL OUT | | D1040Q | Electrovalve, Audible Alarm or other devices | | 4 | 24 Vdc | SIL 2 Bus Powered | |
| | | D1041Q | LED | Voltage free Contact, Logic Level, Loop powered 24 Vdc from DCS, PLC or other control devices | 4 | | or | SIL 3 Loop Powered |
| | | D1042Q | Electrovalve, Audible Alarm or other devices | | 4 | | | |
| | | D1043Q | Electrovalve, Audible Alarm or other devices | | 4 | | | |
| | | D1044S | SPDT (relay contact) | Voltage free Contact, Logic Level, Bus/Loop powered 24 Vdc from DCS, PLC or other control devices | 1 | 24 Vdc | SIL 2 Independ. Channels | |
| | | D1044D | | | 2 | | SIL 3 1oo2 Channels | |
| | | D1045Y | Electrovalve, Audible Alarm or other devices | Voltage free Contact, Logic Level, Loop powered 24 Vdc from DCS, PLC or other control devices | 2 alternate | 24 Vdc | - | |
| | | D1046Y | | | 2 alternate | | - | |
| | | D1048S | NE Electrovalve, Audible Alarm or other devices Line/Load fault detection | Loop Powered control signal from safety PLC, DCS | 1 | 24 Vdc | SIL 3 | |
| | | D1049S | | Voltage free Contact, Logic Level, from DCS, PLC or other control devices. Bus powered | 1 | | SIL 3 | |
| | SIGNAL CONV. | | D1052S | 4-20 mA, 0-20 mA 1-5 V, 0-5 V, 2-10 V, 0-10 V | 4-20 mA, 0-20 mA (source) or 1-5 V, 0-5 V, 2-10 V, 0-10 V | 1 | 12-24 Vdc | - |
| | | | D1052D | from 3/4-Wires powered Tx or other instrument | | 2 | | - |

| | Field device | Model | Hazardous Area | Safe Area | Ch. per unit | Supply | SIL level |
|--------------------------------|--------------|---------------|------------------------------------------------------------------------|---------------------------------------------------------------------------------------|--------------|----------------|-----------|
| SIGNAL CONV. + TRIP AMPLIFIERS | | D1053S | 4-20 mA, 0-20 mA 1-5 V, 0-5 V, 2-10 V, 0-10 V | 4-20 mA, 0-20 mA (source) | 1 | 24 Vdc | |
| | | D1054S | 4-20 mA, 0-20 mA 2/3-Wires Tx, Smart compatible | or 1-5 V, 0-5 V, 2-10 V, 0-10 V Independent set points via SPST Relays | 1 | 12-24 Vdc | |
| | | D1073S | Universal TC, 3/4-Wires RTD, Potentiometer, mV | | 1 | 24 Vdc | |
| | | D1060S | 0-50 KHz Magnetic Pickup or Proximity Switch | mA (source) or V Out, Pulse repeater Output + set point SPST Transistor | 1 | 12-24 Vdc | - |
| SERIAL CONV. | | D1061S | RS-485, RS-422 up to 1.5 Mbit/s | RS-485, RS-422, RS-232 | 1 | 24 Vdc | - |
| VIBRATION INTERFACE | | D1062S | Vibration Transducers, Accelerometers, 2/3-Wires sensors | Transparent input repeater | 1 | 24 Vdc | - |
| LOAD CELLS ISOLATOR CONV. | | D1063S | Up to 4, 350 Ω, 6-Wires Load Cells in parallel. | Transparent input repeater. | 1 | 24 Vdc | - |
| | | D1064S | | mA (source or sink) and V Output and MODBUS RTU | 1 | | |
| DIGITAL IN 3-WIRES SENSOR | | D1080D | 3-Wires Sensors, Electro-optic, photo-cells and other devices | SPST (relay contact) | 2 | 24 Vdc | - |
| | | D1180D | | | 2 | 110-230 Vac | - |
| | | D1081D | | | 2 | 15-24 Vdc | - |

| Field device | Model | Hazardous Area | Safe Area | Ch. per unit | Supply | SIL level |
|------------------------|------------------------|-------------------------------------------------------------------------------|----------------------------------------------------------------------------------------------------------|--------------|--------------|--------------|
| TEMPERATURE CONVERTERS | D1072S | Universal TC, 3/4-Wires RTD, Potentiometer, mV | 4-20 mA, 0-20 mA (source) | 1 | 12-24 Vdc | SIL 2 |
| | D1072D | | 1-5 V, 0-5 V, 2-10 V, 0-10 V | 2 | | SIL 2 |
| | D1072D | | Two duplicated outputs Adder/Subtractor Low/High pass | 1 - 2 | | SIL 2 |
| | D1010S -054 | -5 to +55 mV Thermocouple | 4-20 mA (source) | 1 | 24 Vdc | SIL 3 |
| | D1010S -056 | -5 to +35 mV Thermocouple. | Fast response time for temperature measurements in critical applications (i.e: gas turbines) | 1 | | SIL 3 |
| | D1010S -057 | -5 to +10 mV Thermocouple. | 1 | SIL 3 | | |
| SHUNT RESISTOR | D1090Q | Separately powered 4-20 mA, 0-20 mA | 10 to 50 mV or 0 to 50 mV to D2010M, D2011M | 4 | - | - |
| | D1094Q | Separately powered 0-5 V, 0-10 V | 0 to 20 mV or 0 to 40 mV to D2010M, D2011M | 4 | - | - |
| POWER SUPPLIES | | for more information and details about Power Supplies, see section at page 75 | | | | |
| SAFETY RELAYS | | for more information and details about Safety Relays, see section at page 33 | | | | |

| Image | Code | Description |
|-------------------------------------------------------------------------------------|-----------------|----------------------------------------------------------------------------------------------------------------|
|  | MCHP065 | DIN-Rail Anchor for terminal block side of the Power Bus |
|  | MCHP139 | 5 mm spacer for modules on DIN-Rail |
|  | MOR016 | DIN-Rail Stopper |
|  | MOR015 | Plug-in terminal block male, vertical out, for Power Bus |
|  | MOR017 | Plug-in terminal block male, horizontal out, for Power Bus |
|  | MOR022 | Plug-in terminal block female, horizontal out, for Power Bus |
|  | OPT1091 | Cold Junction Compensator for TC Input |
|  | OPT1096 | Kit for Bus Mounting includes: 2 x MOR016, 1 x MOR017, 1 x MOR022, 2 x MCHP065 |
|  | /B | Power Bus Enclosure |
|  | D1091S | Common Bus Alarm Module with SPDT Relay Fault Output indication |
|  | PPC1090 | Pocket Portable Configurator with cables |
|  | PPC1092 | RS-232 Serial Adapter for Configuration via PC, includes USBADAPT and cables |
|  | USBADAPT | USB to RS-232 Adapter for PC |
|  | SWC1090 | PC Software for Configuration (free of charge at www.gmint srl.com) |

EI1000ADP SERIES

G.M. International offers continuity in the service of Elcon Instruments 1000 series (no longer available from the manufacturer).

Features

- ATEX, FM, FM-C Certifications
- Interchangeability with Elcon 1000 Series modules
- Possibility to replace Elcon modules without modifying any wiring or connections
- Use of the same Elcon boards
- Identification using the same Elcon part-number



| Model | Description | Ch. |
|---------------------------------------------------------------|----------------------------------------------------------------------------------------------------|-----|
| Analog Input, Power Supply Repeaters | | |
| 1021 | Analog Input Repeater, Smart Tx Compatible (non Honeywell Compatible) | 1 |
| 1022 | Analog Input Repeater, Smart Tx Compatible (non Honeywell Compatible) | 2 |
| 1023 | Analog Input Repeater, Floating Output | 1 |
| 1025 | Analog Input Repeater, Smart Tx Compatible | 1 |
| 1025G | Analog Input Repeater, Smart Tx Compatible, 3 Port Isolation, $I_{sc}=93mA$ for wider applications | 1 |
| 1026 | Analog Input Repeater, Smart Tx Compatible | 2 |
| 1026G | Analog Input Repeater, Smart Tx Compatible, 3 Port Isolation, $I_{sc}=93mA$ for wider applications | 2 |
| 1029 | Analog Input Repeater, Smart Tx Compatible Sink/Source Output, $I_{sc}=93mA$ for wider applic. | 1 |
| 1030 | Analog Input Repeater, Smart Tx Compatible Sink/Source Output, $I_{sc}=93mA$ for wider applic. | 2 |
| Analog Input, Power Supply Repeater and Trip Amplifier | | |
| 1020 | Analog Input (Tx or Current Source), Analog Repeater and 1 Set point Trip Amplifier | 1 |
| 1027 | Analog Input (Tx or Current Source), Analog Repeater and 2 Set point Trip Amplifiers | 1 |
| Analog Output, Powered Isolating Drivers for I/P | | |
| 1031 | Analog Output Isolating Driver, Bus Powered | 1 |
| 1032 | Analog Output Isolating Driver, Bus Powered | 2 |
| 1033 | Analog Output Isolating Driver, Bus Powered (Not Loop Powered) | 1 |
| 1034 | Analog Output Isolating Driver, Bus Powered (Not Loop Powered) | 2 |
| 1037 | Analog Output Isolating Driver, Bus Powered for Smart I/P and Positioner | 1 |
| 1038 | Analog Output Isolating Driver, Bus Powered for Smart I/P and Positioner | 2 |

| Model | Description | Ch. |
|-------------------------------------------------------------------------|--------------------------------------------------------------------------------------------------|-----|
| Fire and Smoke Detectors Repeaters | | |
| 1035 | Loop Powered Isolator for Fire and Smoke Detectors | 1 |
| 1036 | Loop Powered Isolator for Fire and Smoke Detectors | 2 |
| 1039 | Loop Powered Isolator for Fire and Smoke Detectors, I _{sc} =93mA for wider applications | 1 |
| 1040 | Loop Powered Isolator for Fire and Smoke Detectors, I _{sc} =93mA for wider applications | 2 |
| Analog Signal and Temperature Converters Fully Programmable | | |
| 1011 | mA or V Input, mA or V Output | 1 |
| 1012 | mA or V Input, mA or V Output | 2 |
| 1061 | TC or mV Input, mA or V Output (Temperature Linear Output) | 1 |
| 1062 | TC or mV Input, mA or V Output (Temperature Linear Output) | 2 |
| 1065 | TC or mV Input, mV Output (mV Linear Output) | 1 |
| 1066 | TC or mV Input, mV Output (mV Linear Output) | 2 |
| 1071 | RTD or Potentiometer Input, mA or V Output (Temperature Linear Output) | 1 |
| 1072 | RTD or Potentiometer Input, mA or V Output (Temperature Linear Output) | 2 |
| 1073 | RTD or Potentiometer Input, mA or V Output (Temperature Linear Output) and 3 Port Isolation | 1 |
| 1074 | RTD or Potentiometer Input, mA or V Output (Temperature Linear Output) and 3 Port Isolation | 2 |
| 1090 | Strain Gauge or Load Cell Input, mA or V Output | 1 |
| Digital Input Switch/Proximity Repeater | | |
| 1821 | Switch/Proximity Input Repeater, Relay Output (DPDT) | 1 |
| 1822 | Switch/Proximity Input Repeater, Relay Output (SPDT) | 2 |
| 1841 | Switch/Proximity Input Repeater, Transistor Output | 1 |
| 1842 | Switch/Proximity Input Repeater, Transistor Output | 2 |
| Digital Output Drivers for Solenoid Valves, LEDs, Horns | | |
| 1861 | SPDT Relay Output | 1 |
| 1862 | SPDT Relay Output | 2 |
| 1871 | Digital Output Driver for Solenoid Valves | 1 |
| 1872 | Digital Output Driver for Solenoid Valves | 2 |
| 1873 | Digital Output Driver for Solenoid Valves | 1 |
| 1874 | Digital Output Driver for Solenoid Valves | 2 |
| 1881 | Digital Output Driver for Solenoid Valves | 1 |
| 1882 | Digital Output Driver for Solenoid Valves | 2 |
| Frequency to Analog Converter + Pulse Repeater | | |
| 1891 | Pulse Input, Proximity or Magnetic Sensor, mA or V Output and Pulse Repeater | 1 |
| 1893 | Pulse Input, Proximity or Magnetic Sensor, Pulse Repeater | 1 |
| Analog Signal and Temperature Trip Amplifiers Fully Programmable | | |
| 1310 | mA or V Input, 1 Set point, Relay Output, 1 x DPST | 1 |
| 1311 | mA or V Input, 2 Set points, Relay Output, 2 x SPST | 1 |
| 1360 | TC or mV Input, 1 Set point, Relay Output, 1 x DPST | 1 |
| 1361 | TC or mV Input, 2 Set points, Relay Output, 2 x SPST | 1 |
| 1370 | RTD or Potentiometer Input, 1 Set point, Relay Output, 1 x DPST | 1 |
| 1371 | RTD or Potentiometer Input, 2 Set points, Relay Output, 2 x SPST | 1 |
| 1901 | mA or V Input, 2 Set points, Relay Output, 2 x SPST, Non Intrinsically Safe | 1 |





D6000 SERIES

ENHANCED GALVANIC ISOLATORS
SUITABLE FOR SIL 2 APPLICATIONS



D6000

CHARACTERISTICS

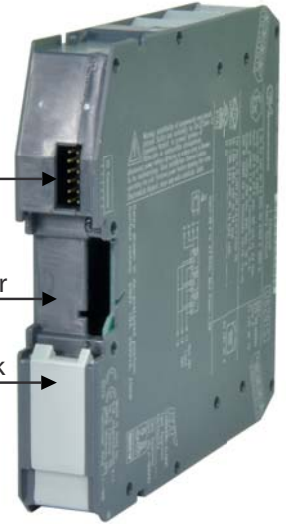

Termination Board connector

Power Bus connector

DIN-Rail lock

Guides for Termination board mounting

Laser engraved Control room Terminal Blocks

Lexan detachable front cover

LEDs for power, status and fault indication are visible through the transparent cover

Modules are SIL 2 certified

Field Terminal Blocks indicator

120 mm

123 mm

12.5 mm

Laser engraving on entire enclosure and terminal blocks to provide accurate, safe and permanent marking of parameters, schematic diagrams, connections and instructions.

D6200 DIMENSIONS

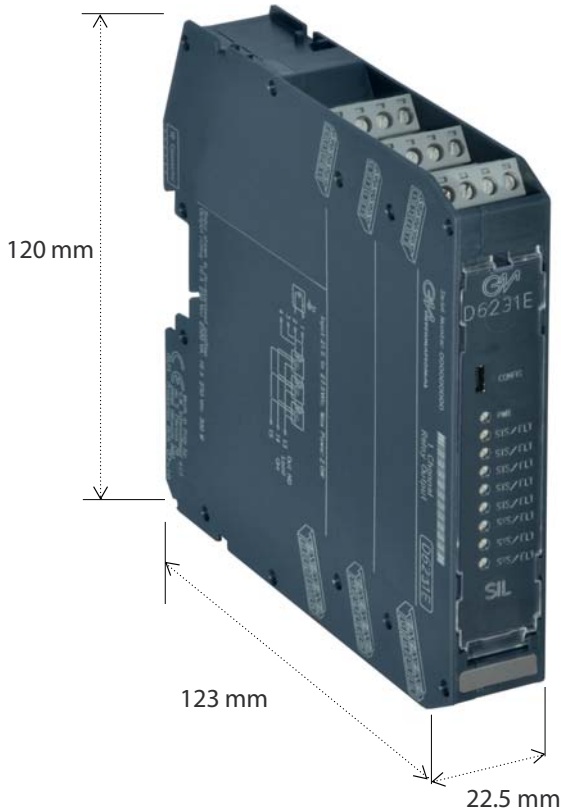

General Features

- Modules suitable for SIL 2 applications according to IEC61508, IEC61511
- Single or multichannel versions available
- Configuration components are easily accessed by removing the side cover
- DIP switch configurability for easy field setup
- LED indication for power, signal status and line fault conditions
- Modules accept DC power supply over a wide range for 24 Vdc (20-30 Vdc) applications
- Wide operating temp. range: -40 to +60/+70 °C

Terminal Blocks for
Field connections

Terminal Blocks for connection
to control room

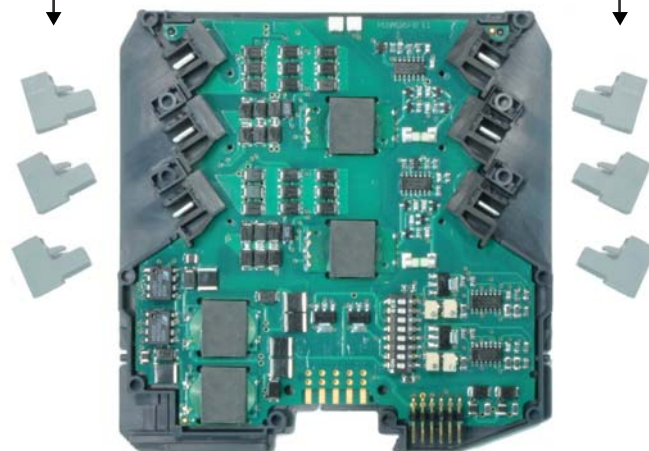

For enclosure characteristics, Power Bus, Termination Board mounting and configuration tools refer to D5000 Series (see pages 21-26)

High Performance

- High signal transfer accuracy and repeatability
- Advanced circuitry provides very low heat dissipation, ensuring modules run cool despite their high density and functionality
- SMD manufacturing for a long, reliable life
- Complete absence of electrolytic capacitors ensures minimum 20 years lifetime









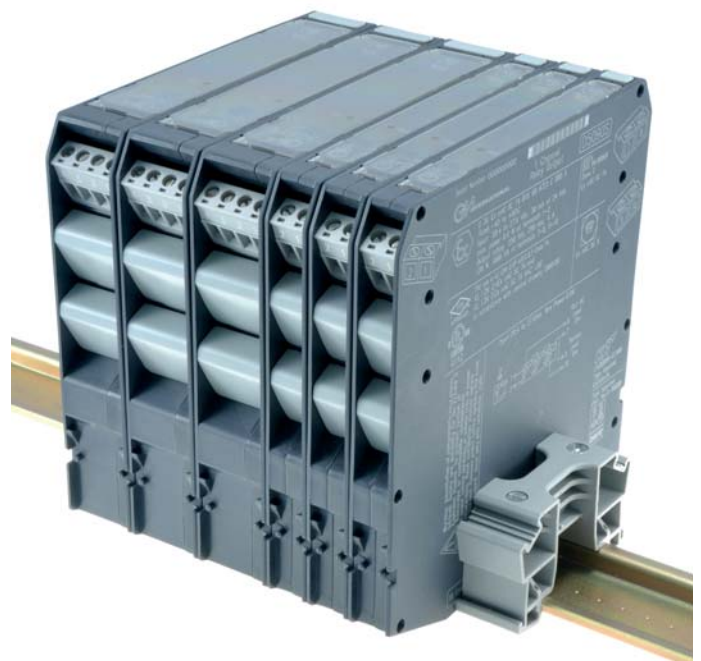













High Packing Density

- High packing density
- 35 mm (Top Hat) DIN-Rail
- Ultra slim 2 channels 12 mm wide DIN-Rail and Termination Board mounting modules
- Power and fault on bus connectors
- 6 mm per channel means 50% space reduction









Wide Functionality

- Wide range of digital and analog I/O
- Three port galvanic isolation to eliminate noise, ground loop problems
- Line fault alarm detects open or short circuit of field cables
- Optional power bus DIN-Rail connector
- Standard Termination Board with custom connectors for integration into customized Boards
- EMC Compatibility to EN61000-6-2, EN61000-6-4, EN61326-1, EN61326-3-1 for safety system



| Field device | Model | In | Out | Ch. per unit | Supply | SIL level | |
|--------------|---------------------------------------------------------------------------------------------------|--------------------------------------------------------------------------------------------------------------|--------------------------------------------------------------------------------------------------------|-------------------------------------------------------------------|------------------------------------------------------------------------------|---------------------------------------------------------------------------------------|---------------------------------------------------------------------------------------|
| ANALOG IN |  D6011S | 4-20 mA 2-Wires passive Tx; Smart compatible | 4-20 mA (source) | 1 | 24 Vdc |  | |
| |  D6011D | | | 2 | |  | |
| |  D6014S | 4-20 mA 2-3-4 Wires Active or Passive Tx; Smart compatible | 4-20 mA (source or sink) | 1 | 24 Vdc |  | |
| |  D6014D | | | 2 | |  | |
| |  D6014D | | | 1 in 2 out | |  | |
| |  D6212Q | 4-20 mA 2-Wires Passive Tx | | 4-20 mA + Modbus | 4 | 24 Vdc |  |
| |  D6212Q | | | Two duplicated outputs + Modbus | 2 in 4 out | |  |
| |  D6212Q | | | One Triplicated + One single outputs + Modbus | 2 in 4 out | |  |
| |  D6212Q | | | One Quadruplicated output + Modbus | 1 in 4 out | |  |
| |  D6254S | | | 4-20 mA, 2/3/4-Wires Tx Active or Passive; Smart compatible | 4-20 mA, 2 Trip Amplifiers each with 1 SPST (relay ontact) + Modbus | | 1 |
| ANALOG OUT |  D6020S | 4-20 mA Analog Signal to I/P Converters, Electrovalves, Actuators and Displays; Smart compatible | 4-20 mA Bus powered signal from DCS, PLC or other control devices. Two duplicated outputs. | 1 | 24 Vdc |  | |
| |  D6020D | | | 2 | |  | |

| | Field device | Model | In | Out | Ch. per unit | Supply | SIL level |
|-----------------------------------------------|--------------|---------------|--------------------------------------------------------------------------------------|----------------------------------------------------------------------------------------|---------------|-----------|--------------|
| DIGITAL IN | | D6030S | | SPDT (relay contact) + LED (fault status) | 1 | | SIL 2 |
| | | D6030D | Voltage free Contact, Proximity Switch Line fault detection Isolated inputs | SPST (relay contact) + SPST (alarm or duplicator) + LED (fault status) | 1 in 2 out | 24 Vdc | SIL 2 |
| | | D6030D | | SPST (relay contact) + LED (fault status) | 2 | | SIL 2 |
| | | D6031S | | Open Collector + LED (fault status) | 1 | | SIL 2 |
| | | D6031D | Voltage free Contact, Proximity Switch Line fault detection Isolated inputs | Open Collectors + O.C. (alarm duplicator) + LED (fault status) | 1 in 2 out | 24 Vdc | SIL 2 |
| | | D6031D | | 1 Open Collector + LED (fault status) | 2 | | SIL 2 |
| | | D6231E | Voltage free Contact, Proximity Switch Line fault detection | Open Collectors + LED (fault status) + Modbus | 8 | 24 Vdc | SIL 2 |
| TEMPERATURE CONVERTERS AND TRIP AMPLIFIERS | | D6072S | Universal TC, 3/4-Wires RTD, Potentiometer, mV | 4-20 mA (source or sink) + Modbus Independent set point via Solid State Relay | 1 | 24 Vdc | SIL 2 |
| | | D6072D | Universal TC, 3-Wires RTD, Potentiometer, mV | 4-20 mA (source or sink) + Modbus Duplicator | 1 in 2 out | 24 Vdc | SIL 2 |
| | | D6072D | | 4-20 mA (source or sink) + Modbus | 2 | | SIL 2 |
| | | D6273S | Universal TC, 3/4-Wires RTD, Pot, mV | 4-20 mA (source or sink) Independent set points via SPDT Relay each + Modbus | 1 | 24 Vdc | SIL 2 |

| Image | Code | Description |
|-------------------------------------------------------------------------------------|----------------|-----------------------------------------------------------------------------------------|
|  | JDFT049 | 12 mm Power Bus Connector for DIN Rail Mounting 1 needed for each BUS Module |
|  | JDFT050 | 22 mm Power Bus Connector for DIN Rail Mounting 1 needed for each BUS Module |
|  | MCHP196 | Bus End Stopper One required for each end of Bus |
|  | MOR017 | Plug-in terminal block male, horizontal out, for Power Bus |
|  | MOR022 | Plug-in terminal block female, horizontal out, for Power Bus |
|  | OPT5096 | Kit for Bus Mounting includes: 1 x MOR017, 1 x MOR022, 2 x MCHP196 |
|  | PPC5092 | PC Adapter required to configure programmable units; Mini USB Male cable to USB Port |
|  | SWC5090 | PC Software for Configuration |



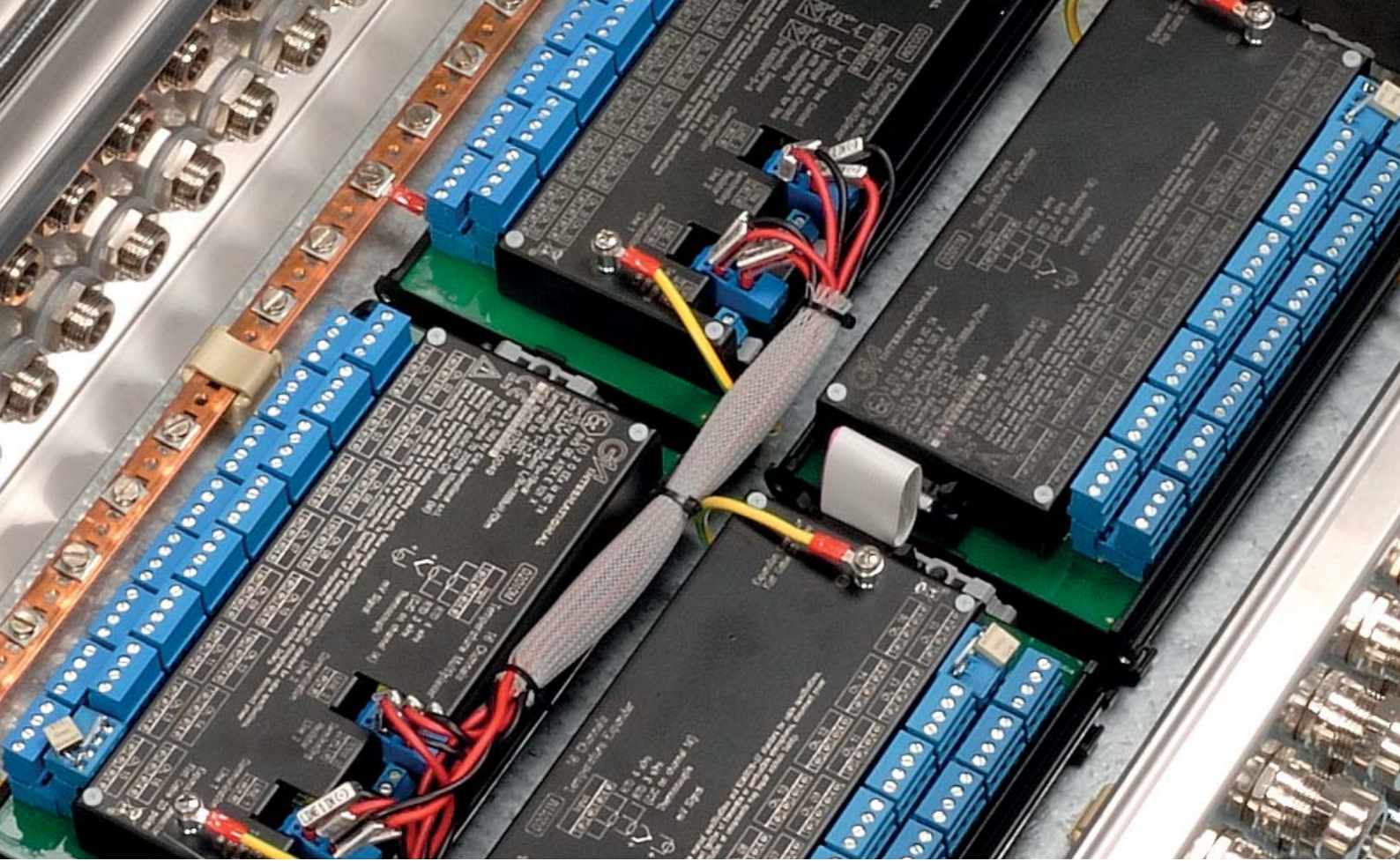

D2000 SERIES

INTRINSICALLY SAFE MULTIPLEXER
FOR ANALOG AND DIGITAL INPUTS FROM ZONE 0

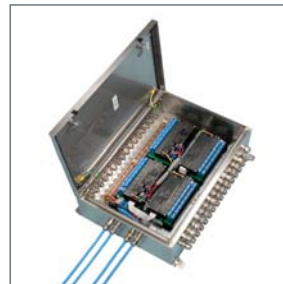

D2000

CHARACTERISTICS

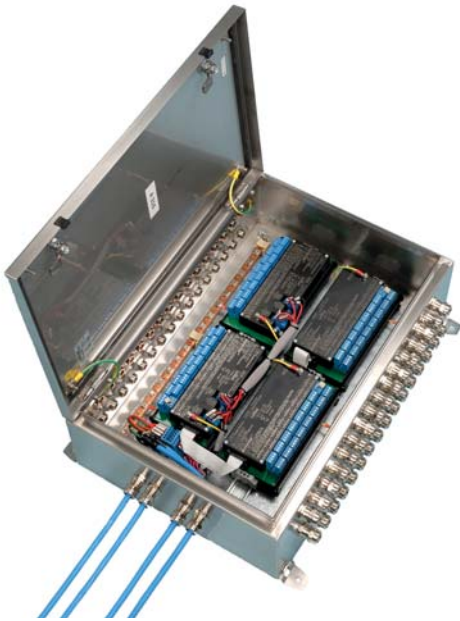

Features

- High density, up to 256 Analog Inputs (TC, RTD, mV) and up to 128 digital inputs (contact / proximity) in the same system (expandable up to 7936 inputs)
- High accuracy 18 bit A/D converter
- Robust Isolation ($\pm 200V$ test voltage channel to channel), provides high immunity against interference and ground loops
- Intrinsically safe for installation in Zone 1 or 2
- Field units can be placed up to 4 km from Gateway
- Redundant communication lines
- Programmable via PC (RS232) and Modbus (RS485)
- Repeats input contacts via Relay or Transistor outputs
- Reduces field wiring and installation costs
- Eliminates the need of PLC - DCS I/O cards
- Field unit operating temperature: $- 40$ to $+ 60$ °C
- AISI 316 stainless steel enclosures are available for field units (Series GM2300)
- Gateway D2050M can be installed in Zone 1 / Div. 1 by using an explosion proof enclosure

SWC2090 Software Configurator

- Configure and monitor the entire system with your PC / Laptop via RS232 and/or RS485 connections
- Guided user interface
- Print complete report sheets
- Save configurations to file for backup
- Multilanguage

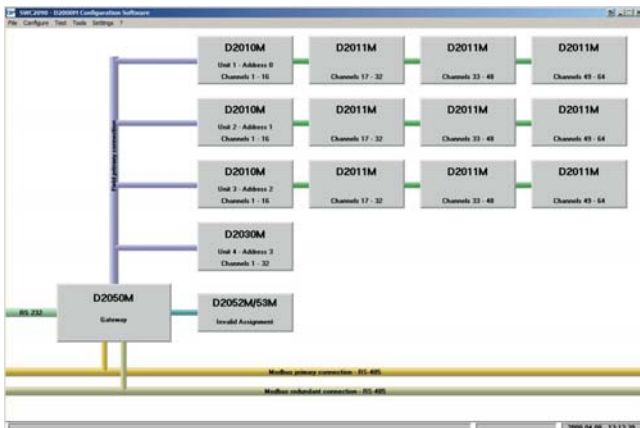

D2050M

Gateway/Power Supply Multiplexer Unit

- II (1) G [Ex ia Ga] IIC
- Supply 24 Vdc
- Redundant MODBUS RTU - RS485 lines up to 115200 bauds
- RS-232 line for configuration via PC
- Suitable to drive contact/proximity output repeaters
- Safe Area Installation or Zone 1 / Div 1 when mounted in an explosion proof housing
- Operating Temperature - 20 to + 60 °C.



D2010M
D2030M

D2010M - D2011M

Analog/Temperature Multiplexer Unit

- II (1) 2G Ex ia [ia Ga] IIC T4 Gb
- 16 Channels per Unit, each for 2-3-4 wires RTD, Pt100, Pt50, Ni100, Cu100, Cu53, Cu50, Cu46, TC Type A1, A2, A3, B, E, J, K, L, Lr, N, R, S, T, U.
- Up to 16 Units per gateway
- 256 Channels are scanned in 1700 ms
- Redundant Communication with D2050M gateway
- PC Programmable via SWC2090 software
- Zone 1 / Div. 1 Installation
- Operating Temperature - 40 to + 60 °C



D2030M

Switch/Proximity Multiplexer Unit

- II (1) 2G Ex ia [ia Ga] IIC T4 Gb
- 32 Channels per Unit
- Input from Contact-Proximity Sensors
- Up to 4 Units per System
- 128 Channels are scanned in 50 ms
- Redundant Communication with D2050M Gateway
- PC Programmable via SWC2090 software
- Zone 1 / Div. 1 Installation
- Operating Temperature - 40 to + 60 °C

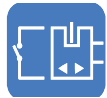

D2052M - D2053M

Contact/Proximity Output Repeater

- 32 Isolated Channels with SPDT Relay contacts (D2052M) or Open Collector Transistors (D2053M)
- up to 4 Units per gateway
- 128 Channels are scanned in 50 ms
- Safe Area Installation or Zone 1 / Div. 1 when mounted in an explosion proof housing
- Operating Temperature - 20 to + 60 °C



SYSTEM ARCHITECTURE

D2000 Multiplexer accepts both analog and digital inputs in the same system allowing the user to choose whatever configuration fits his application best in terms of cost and cabling. The following are two examples of achievable system architectures.

128 Analog and 64 Digital Inputs. One of the two D2030M digital units is repeated in safe area through a D2052M or D2053M

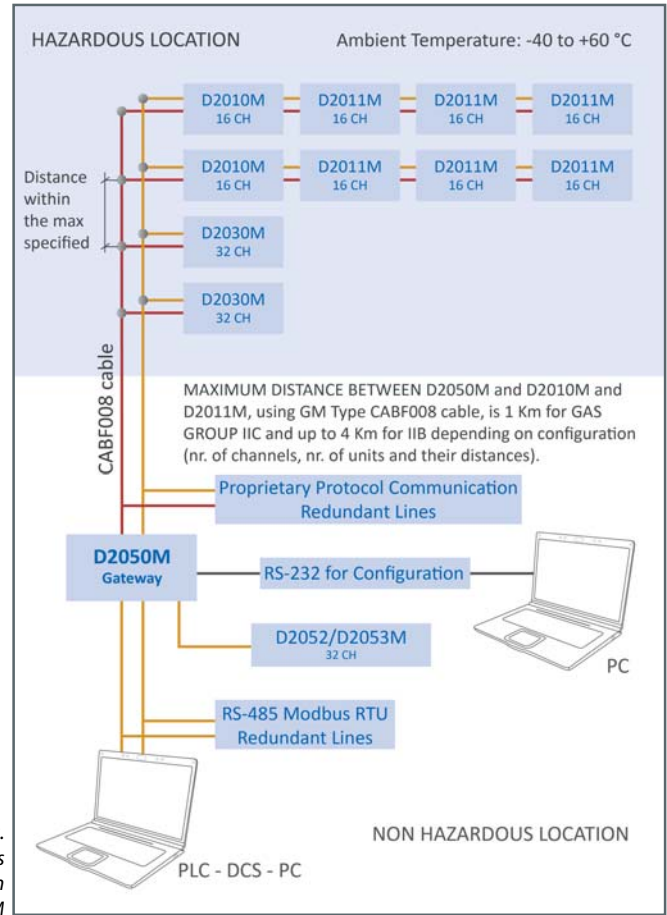

128 Digital Inputs from 4 D2030M slave units in the field and 128 Digital Outputs in Safe Area through repeaters D2052M or D2053M

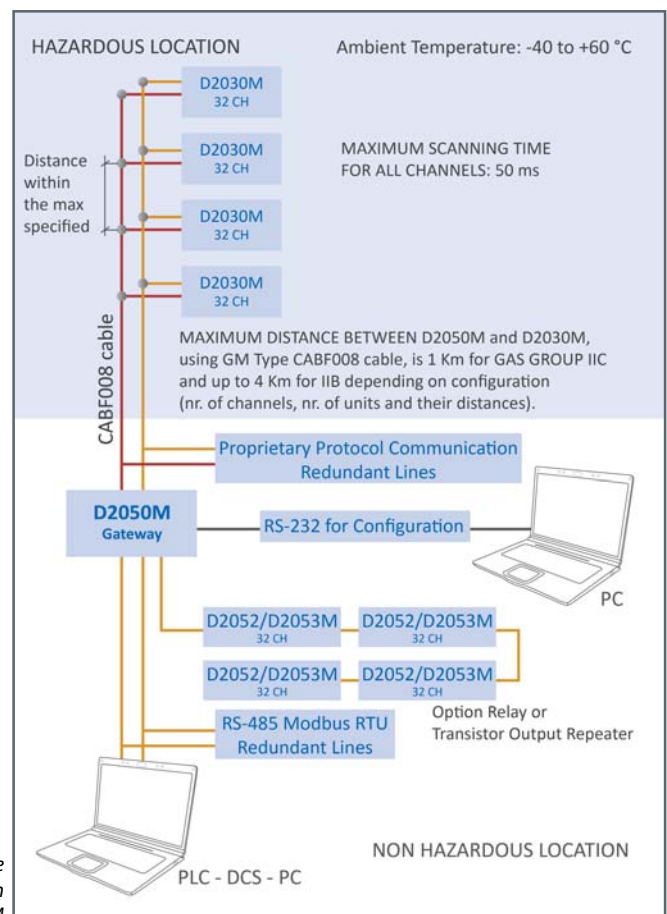

MULTIPLEXING TECHNIQUE

Signal data acquisition

In industrial processes it is a common need to acquire a relevant number of temperatures, pressures, flows, levels and other process variables as well as the status of switches or proximity sensors and to collect all these data in a single remote collection area (i.e. in a control room) where PLC (Programmable Logic Controller) or a Process Computer collects all data for monitoring purposes and availability to operators. SCADA (Signal Conditioning And Data Acquisition) equipments are particularly suited for this purpose. Typical applications are Furnaces, Cracking Towers, Gasifiers, Reactors, Distillers, Separators, Oxidizers, Tank Monitoring, Flare Stacks. Mux system permit fast, accurate and stable Analog to Digital conversion, high speed computing, sophisticated intelligence and powerful measuring capabilities. All this performance can be packed into compact, reliable units that can operate in harsh environments.

Multiplexers are a typical SCADA multi channel equipment that can be located in the field close to the process area where the input channels can be connected with shorter lines. All input channel signals are converted in a numeric form and transmitted to a remote location via a single or redundant communication line.

The advantages of multiplexing

When a consistent quantity of variables must be made available to a distant location, instead of wiring each process variable signal with long individual connection lines up to the control room, it is advantageous to connect all input signals to a conveniently located field Multiplexer with short connections lines to the sensors. Data is then sent through a single communication line to the remote monitoring area. Even when space for cables is available, the saving in cable costs alone justifies, most of the times, a multiplexer solution; in addition, a tidy simple connection is obtained avoiding cluttering of wires in the control room area. Less cabling is not the only advantage; when using a remote multiplexer there is no longer the need to use Transmitters, Safety Barriers and Analog Input channels providing for a drastic price reduction.

Multiplexing in hazardous area

For applications in classified Hazardous Areas each signal must be protected from the risk of causing an ignition of flammable mixtures: this requires a safety barrier for each input channel. By using an Intrinsically Safe multiplexer solution, protection must be applied only to the communication lines, decreasing complexity, maintenance and costs.







When multiplexing is the only solution

In case of revamping or expansion in the plant, the space for adding cables may be limited or the few existing spare cables may be the only ones that can be used.

Radio Frequency links, beside costs and licensing problems, suffer data security and reliability issues. Multiplexing often becomes the only practical solution.



| | Field device | Model | Hazardous Area | Safe Area | Ch. per unit | Supply |
|-------------------------------|--------------|---------------|----------------------------------------------------------------------|---------------------------------------------------------------------------|--------------|-----------------------|
| INTRINSICALLY SAFE MULTIPLIER | | D2010M | Universal TC, 3/4-Wires RTD, mV | D2050M Gateway via redundant communication line, up to 4 Km away | 16 | Supplied by D2050M |
| | | D2011M | Universal TC, 3/4-Wires RTD, mV Connected to D2010M | | 16 | |
| | | D2030M | Voltage free contacts, proximity switches Line Fault Detection | 32 | | |
| | | D2050M | Up to 4 units D2010M, D2030M. | RS-485 MODBUS, RS-232 Serial line | - | 24 Vdc |
| | | D2052M | Digital signals from D2030M | Relay, digital repeater | 32 | 24 Vdc |
| | | D2053M | | O.C. Transistor, digital repeater | 32 | |

| Image | Code | Description |
|------------------------------------------------------------------------------------|----------------------------------------------------|-------------------------------------------------------------------------------------------------------------|
|  | D1090Q D1094Q | 4 channels shunt module for mA input 4 channels voltage divider module for V input |
|  | OPT2091 | Cold Junction compensator for TC input |
|  | MOR016 | DIN-Rail Stopper |
|  | CABF005 CABF006 CABF007 | Flat cable to interconnect D2010M with expander units D2011M. Available in 15, 30, 50 cm lengths. |
|  | CABF022 CABF023 CABF024 | Flat cable to interconnect D2050M with repeater units D2052M/D2053M. Available in 15, 30, 50 cm lengths. |
|  | CABF008 | Cable to interconnect D2050M with field units D2010M and D2030M |





POWER SUPPLIES

INTRINSICALLY SAFE AND
NON-INCENDIVE POWER SUPPLIES



POWER SUPPLIES

MODELS

PSD1000

Universal Input Power Supply for D1000 Series Isolators (PS)

- Supply 90 - 265 Vac
- Output 24 Vdc, 500 mA
- 2 Units can be paralleled for redundancy or additional power
- Remote indication for Power Failure for PSD1000F
- Installation adjacent to D1000 Series Modules, without Safety distance of 50 mm, because Supply and Output Terminal Blocks are on the same side
- Zone 2 / Div. 2 installation



PSD1001

SIL 2 / SIL 3 4 Channels Intrinsically Safe Power Supply (PS)

- Supply 24 Vdc
- 4 Independent Outputs 15 V, 20 mA
- Output to Zone 0 / Div. 1
- Zone 2 / Div. 2 installation
- Flexible modular multiple output capability
- Output short circuit proof and current limited
- High Reliability, SMD components
- High Density, four channels per unit
- Simplified installation using standard DIN Rail and plug-in terminal blocks

PSD1001C

SIL 2 / SIL 3 1 Channel Intrinsically Safe Power Supply (PS)

- Supply 24 Vdc
- Output 13.5 V - 100 mA
- Input from Zone 0 / Div. 1
- Zone 2 / Div. 2 installation
- Output short circuit proof and current limited



PSD5201

SIL 3 1 Channel Intrinsically Safe Power Supply (PS)

- Supply 24 Vdc
- 1 Output 14.5 V - 150 mA
- Output to Zone 0 / Div. 1
- Zone 2 / Div. 2 installation

PSW1250

SIL 3 Universal Input Power Supply

24 Vdc, 50 A, Zone 2 / Div. 2 Installation Suitable for Parallel Operations

- Supply 100 - 264 Vac
- Power Factor correction
- Output 24 Vdc, 50 A; regulated and adjustable from 21 to 28 Vdc.
- Efficiency better than 89% at 230 Vac supply
- Two or more Units can be paralleled for Redundancy or additional power with automatic load sharing
- Two Units in parallel offer AC1 or AC2 redundancy
- Remote indication for Power Failure
- Zone 2 / Div. 2 installation
- ATEX: II 3G Ex nA nC IIC T4 Gc
- IECEx: Ex nA nC IIC T4 Gc
- Three over-voltage redundant protections
- Mosfet Active Ideal Diode instead of Schottky diode reduces power dissipation
- High load fuse breaking capability without interrupting operations
- Wall mounting
- Stainless steel AISI 304 enclosure



Function Diagram Dual AC Supply wiring architecture for PSW1250

PSW1250, dual AC supply, one 50 A Output + one redundant 50 A Output

Two modules connected in parallel to provide full redundancy on AC lines (AC1, AC2); one 50 A redundant output.

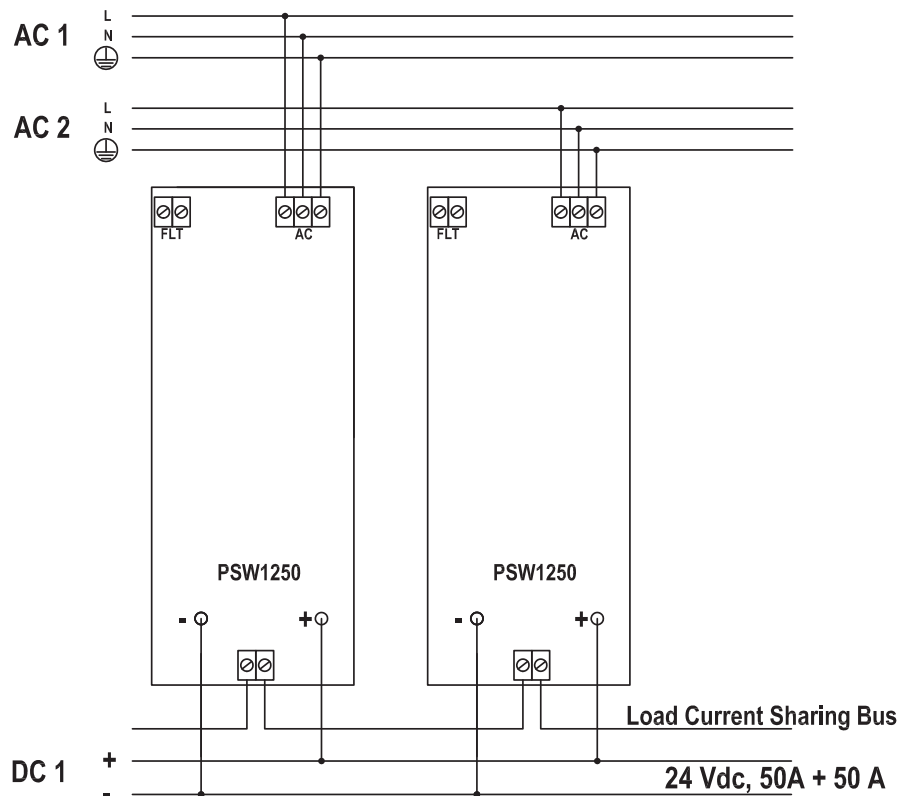

PSS1250

SIL 3 Power Supply System Universal Input,
24 Vdc, 50-100-150 A, Zone 2 / DIV. 2 Installation

The Power Supply System type PSS1250 is an anodized aluminum 19", 9" or 7" Rack unit (4U high) suitable to accept up to six (for 19" rack) or two (for 9"/7" rack) plug-in Power Supply Modules type PSM1250. PSO1250 Overview module for diagnostic functions is available on 19" and 9" racks.

Features

- Supply 100 - 264 Vac
- Power factor correction
- Output 24 Vdc, 50 A per module
- Regulated and adjustable output voltage from 21 to 28 Vdc
- Efficiency better than 89% at 230 Vac supply
- Two or more Units can be paralleled for Redundancy or additional power with automatic load sharing
- Input and Output redundancy
- Remote indication for fault or Power Failure
- Zone 2 / Div. 2 installation
- ATEX: II 3G Ex nA nC IIC T4 Gc
- IECEx: Ex nA nC IIC T4 Gc
- Hot swappable modules (certified for Zone 2) available (HS option)
- Three over voltage redundant protections
- Mosfet Active Ideal Diode instead of Schottky diode reduces power dissipation
- High load fuse breaking capability without interrupting operations
- Wall mounting

Ordering options

- 19", 9" or 7" Rack enclosure
- Hot Swapping (HS) capability
- PSO1250 Diagnostic Module (19" or 9")
- Multiple Output configurations (see data sheet)



7" Rack Enclosure



9" Rack Enclosure



19" Rack Enclosure

CONFIGURATION EXAMPLES

PSS1250-HS-7-3-D

Two AC supplies, three redundant 50 A Outputs, PSO1250 overview module
Six modules connected in parallel in groups of two.

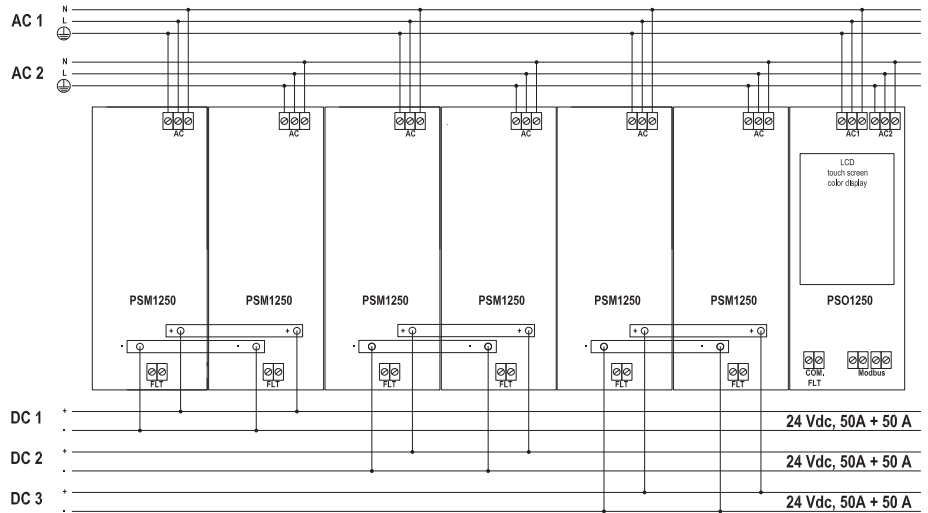
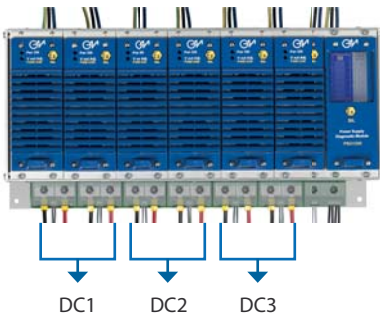

PSS1250-HS-7-2-D

Two AC supplies, one redundant 100 A + one redundant 50 A Outputs, PSO1250 overview module
One group of four modules and one of two modules.

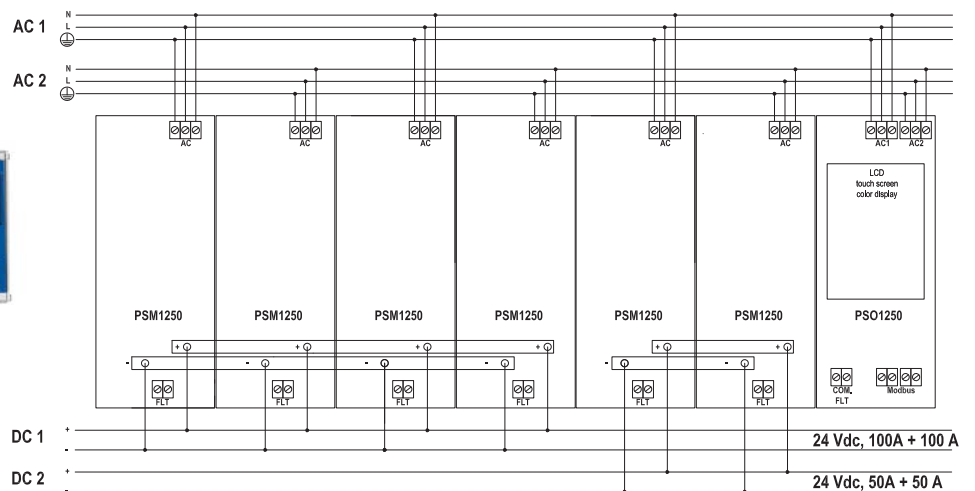
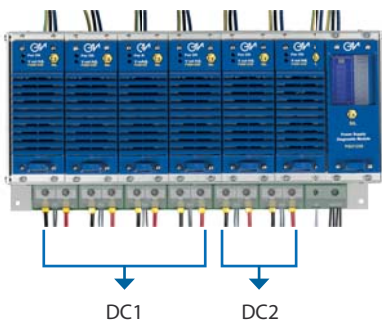

PSS1250-HS-7-1-D

Two AC supplies, one redundant 150 A Output, PSO1250 overview module
Six modules connected in parallel.

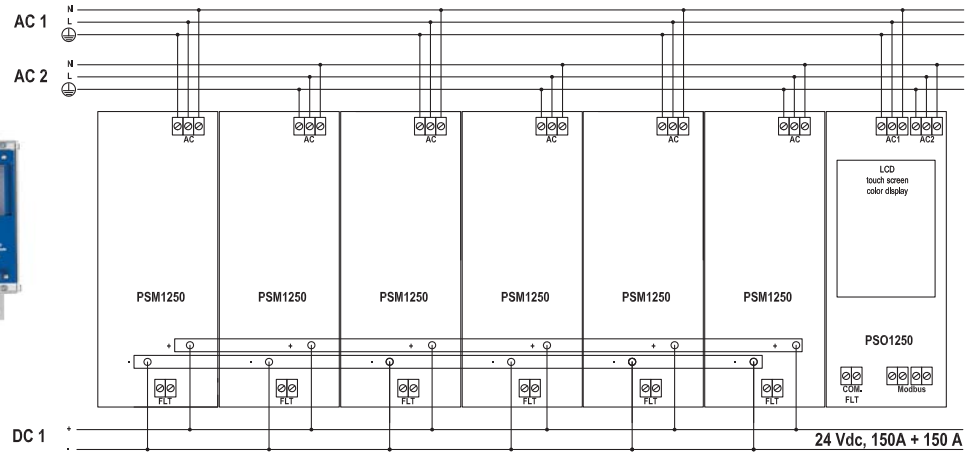
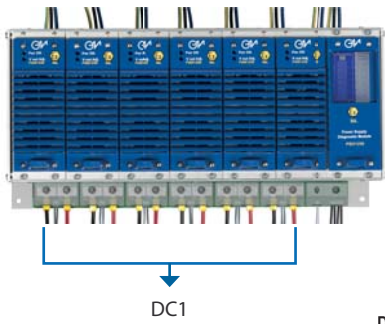

PSS1250-HS-3-D

Two AC supplies, one redundant 50 A Output, PSO1250 overview module
Two modules connected in parallel.

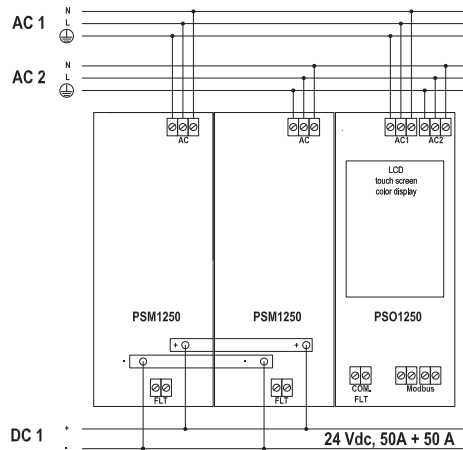

PSS1250-HS-2

Two AC supplies, one redundant 50 A Output
Two modules connected in parallel.

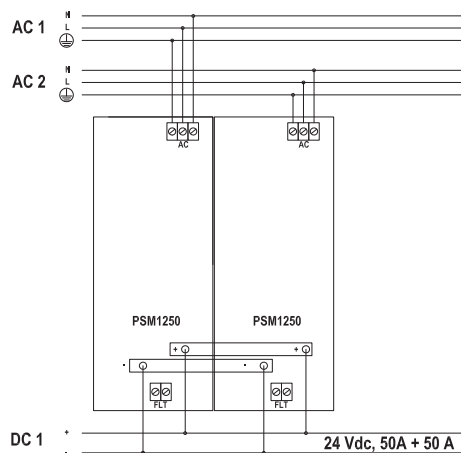

| | Model | Hazardous Area | Output | Ch. per unit | Supply | SIL level |
|----------------|-----------------|-----------------|-----------------------------------------------|-----------------|-------------|------------------|
| POWER SUPPLIES | PSD1000 | Zone 2 / Div. 2 | 24 V, 500 mA to power D1000 Series Modules | 1 | 95-264 Vac | - |
| | PSD1001 | Zone 0 / Div. 1 | 15 V, 20 mA | 4 | 24 Vdc | SIL 3 |
| | PSD1001C | Zone 0 / Div. 1 | 100 mA at 13.5 V | 1 | | |
| | PSD5201 | Zone 0 / Div. 1 | 14.5 V, 150 mA | 1 | 24 Vdc | SIL 3 |
| | PSW1250 | Zone 2 / Div. 2 | 24 V, 50 A | 1 | 100-264 Vac | SIL 3 |
| | PSS1250 | Zone 2 / Div. 2 | 24 V, 50-100-150 A Redundant | up to 6 | 100-264 Vac | SIL 3 |





D9000 SERIES

SURGE PROTECTORS

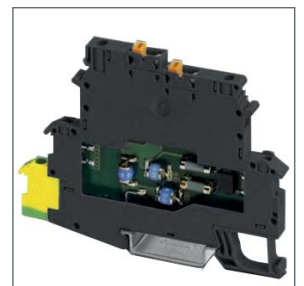

D9000

CHARACTERISTICS

D9000 series provides surge protection for all kinds of applications in different industries such as Oil&Gas, Petrochemical, Steel etc. avoiding signal interruption and protecting control room equipment.

D9024S

Modular Terminal Block DIN Rail surge protector

D9024S modules provide two-stage surge protection for floating I/O signals of measurement and control and safety systems. Its depth of 6mm allows for easy fitting into any marshalling or distribution cabinet.

With disconnect knife on both signal paths features for easy testing of the loop.



D9024S

Features

- SIL 3 according to IEC 61508:2010 Ed.2
- Input from Zone 0 (Zone 20), installation in Zone 1 and 2
- Disconnection of signal circuit by disconnect knife
- Protection of a floating double wire in intrinsically safe circuits
- High Density, 6.2 mm per channel
- HART compatible
- Covers available to terminate a row of D9024S



D9024S

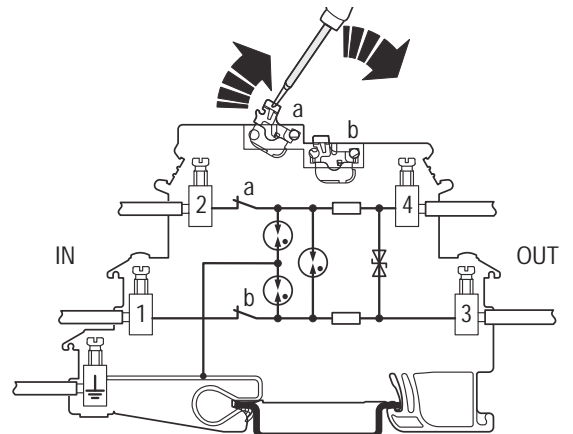

a. Screwdriver operable switch on line between terminals 2 and 4.
b. Screwdriver operable switch on line between terminals 1 and 3.

D9324S

½ inch NPT connection screw-on surge protector

D9324S provides surge protection for floating I/ O signal circuit in screw-on module with IP67 protection for sensor heads, connection ½ inch 14 NPT. Its capability to be installed on explosion proof enclosures guarantees suitability also for a wider range of applications.



D9324S

Features

- SIL 3 according to IEC 61508:2010 Ed.2
- Input from Zone 0 (Zone 20), installation in Zone 1 and 2
- Protection of a floating double wire in intrinsically safe circuits
- Suitable for explosion proof enclosures
- HART compatible

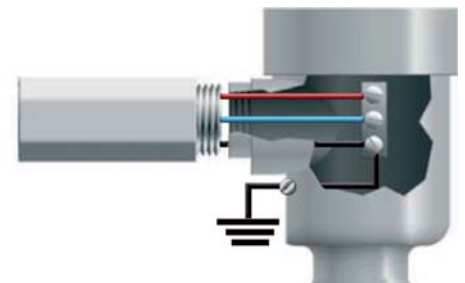

Blue and brown: Floating circuit lines
Black: Earth connection





T3000 SERIES

4 ½ DIGIT LOOP INDICATOR
INSTALLATION IN ZONE 0



T3000

CHARACTERISTICS

Signal Data Acquisition

- ATEX, FM & FM-C, Russian certifications
- Large LCD Display, 20 mm high
- Limited voltage drop (less than 1 V)
- IP66 Enclosure with 2 separated chambers
- Wall, Pipe-Post, or Panel mounting
- Zone 0, IIC T5 / T6 or Div. 1 Installation
- In-field configurability via dedicated push-buttons
 - decimal point
 - indicated range between -19999 and +19999
 - direct or reverse indication
- Under and Over range detection via blinking display
- Protected slot available for engineering value label



Mounting options

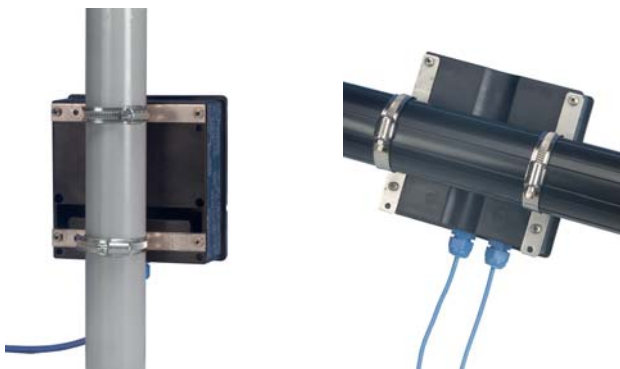

4 ½ Digit Loop Powered Indicator

T3010S offers process variable reading in Hazardous Area.

It is a loop powered 4-20 mA unit with less than 1 V voltage drop and monitors 4-20 mA current, 0-100 % percentage or process variables between -19999 to +19999 range with a 20 mm height 7-segments LCD display. Blinking display indicates over-range or under-range condition.

An internal protected slot-in label is provided, after the last digit, to allow unit measurement indication.

Loop tag indication can be also provided.

The indicator is housed in a molded reinforced polyamide 66 / polycarbonate IP 66 case to allow installation in field area. It can be mounted on flat surface, front panel or 2" pipe or post. The housing is divided in two parts, one for cable connection and the other for indicator parameters setting.

Function Diagram

T3010S units can be connected in series to a 4-20 mA loop (figure A) or can be driven from Safe Area to provide local indication in Hazardous Areas up to Zone 0 / Div. 1 (figure B).

In both cases, the unit must be protected by a suitable intrinsically safe barrier.

Please check data sheet for further information.

Figure A

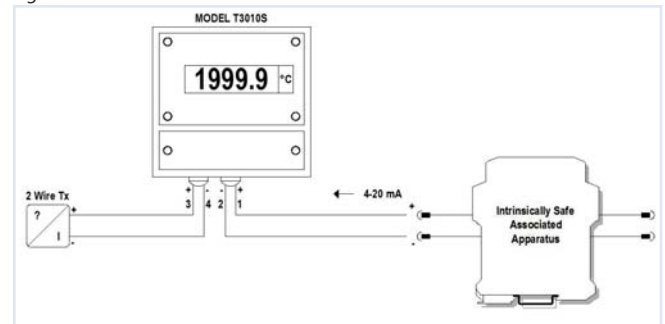
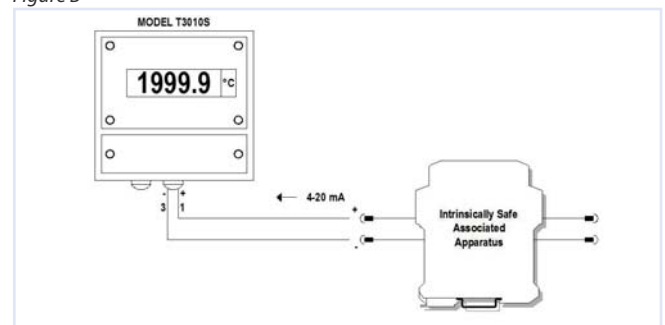

Figure B







ONLINE INFORMATION

A wide range of services and information can be found online at www.gmintsr.com

Download

- Data Sheets
- Instruction Manuals
- Application Notes
- Certificates
- Software

News

- Latest products
- New Certifications
- Worldwide Exhibitions

Utilities

- Online tools for webmasters
- Mailing List
- I.S. Loop verification tool
- Product finder

Products

- Guided model finder
- Series presentation
- Model details
- Advanced search

Contacts

- Agents and Distributors
- Quotation request form
- Technical and Commercial contacts

Data specified in this document are merely descriptive of the products and should be integrated with relevant technical specifications. Our products are constantly being further developed and the information presented herein refers to the latest's product release. No statements concerning a certain condition or suitability for a certain application can be derived from our information. The information given does not release the user from the obligation of own judgment and verification. Terms & Conditions can be found at www.gmintsr.com.



G.M. International s.r.l.
Via G. Mameli, 53-55
20852 Villasanta (MB)
ITALY

www.gmintsr.com
info@gmintsr.com